

Comet Series

Comet-S1000 & S1200

Compact Speed Gate with Elevated Safety

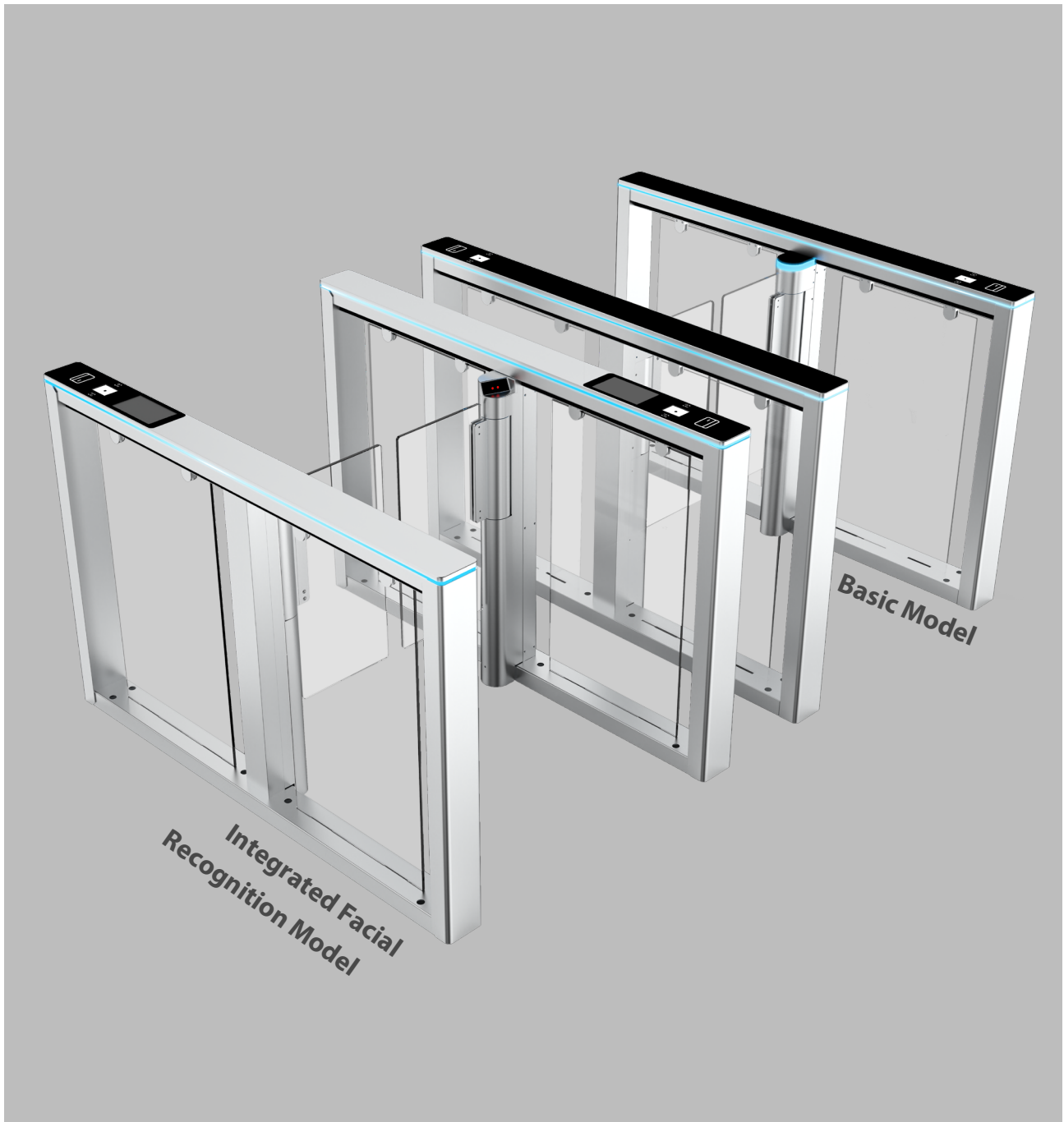

Compatible with
ZKBio CVAccess
ZKBio CVSecurity

Introduction

The Comet Series by ZKTeco is an innovative multi-credential speed gate featuring a sleek, transparent design that fits seamlessly into corporate settings. Available in single-lane and double wings versions, these gates combine advanced functionality with a lightweight yet robust chassis made of distinctive cast aluminum alloy. They offer customizable ambient lighting with 7 RGB colours and are designed for easy installation. The Comet Series revolutionizes facial recognition with eight undercount options and an ultra-wide-angle lens, ensuring optimal performance for individuals of varying heights, including children and seniors with wheelchairs. The series supports biometric, RFID, and QR code options, and offers flexible lane combinations and diverse material choices to meet specific requirements. Security is enhanced with locked positions, clutch engagement, and automatic barrier opening in emergencies.

Multiple Undermount Options

The Comet Series barriers offer a variety of undermount plates to cater to different credential needs. These include:

- RFID
- QR Code
- Fingerprint
- Facial Recognition



Integrated Facial Recognition Model Wide-Angle Undermount Facial

Recognition Camera Design

Covering a height range from 1500mm to 1900mm and offers a recognition distance as far as 1750mm.



Basic model
No Facial Recognition
Camera

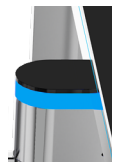

Customizable Ambient Lighting

The Comet Series features customizable ambient lighting, providing a range of 7 RGB colors. This not only enhances the aesthetic appeal of the speed gates but also serves as an indicator, improving usability and enhancing the user experience.

Two Chassis Color Options

The Comet Series provides two color options for its chassis

Silver (SLK)

Gold (GD)

* Note: The illustration shows the under mount facial recognition.

Key Features

Aesthetic Appeal

The Comet Series, the newest addition to ZKTeco's barrier line, features an elegantly slim and transparent design that seamlessly integrates into various indoor environments.

Innovative Cast Aluminium

We harness cutting-edge technology to forge a distinctive aluminium alloy for the barrier chassis. This fusion results in a product that combines the lightweight properties of aluminium with the robustness of an alloy.

Installation-Friendly Design

The Comet Series is designed for ease of installation, featuring newly developed installation rails that can be pre-installed. The barrier is simply placed on the fixed rail to complete the installation, significantly reducing installation time.

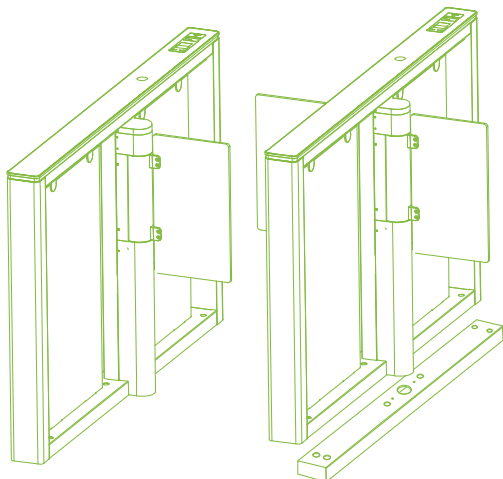

Ambient LED Visual Indicator

An embedded LED strip is situated along the barrier's side, offering a spectrum of 7 RGB colours and a range of visual effects. This feature is fully customizable to meet our customer's unique preferences.

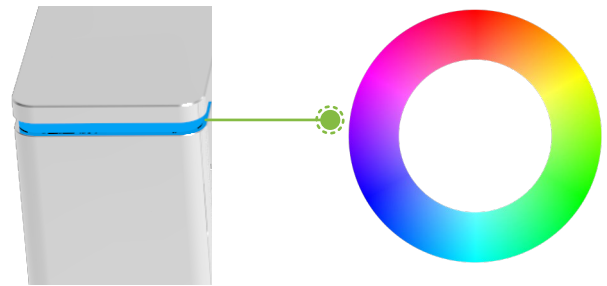

Multi-Credential Compatibility

The Comet series barrier comes with eight different under-mount lid designs and two top-mount accessory sets, offering a variety of credential options including biometric (Face, Fingerprint), RFID and QR codes (steady and dynamic). Customers can select the options that best meet their needs.



Flexible Lane Combination and Options

To cater to diverse installation environments, the Comet series is available in two models: Comet-S1000 & S1200. These can be combined to create multiple-lane solutions. Additionally, the Comet series offers several leaf options in sizes ranging from 660mm to 900mm and in different materials like tempered glass and acrylic, offering the flexibility to meet our customers' specific requirements.

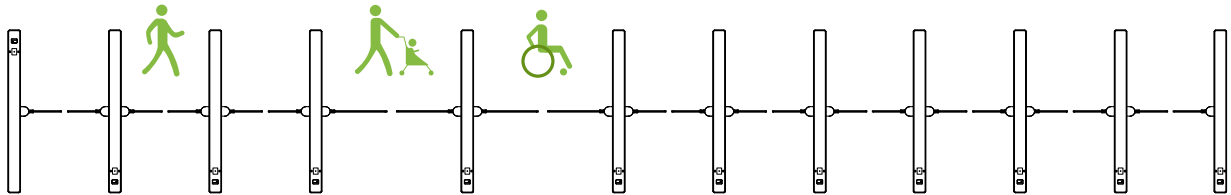

Streamlined Facial Recognition System Integration

To achieve an optimal balance between streamlined design and functionality, we've reimagined our facial recognition system. By repositioning the monitor, PCB, and camera, we've enhanced performance. The camera is strategically placed just above the movement mechanism, offering a superior viewing angle that accommodates individuals of varying heights, including children, the elderly, and people with disabilities.

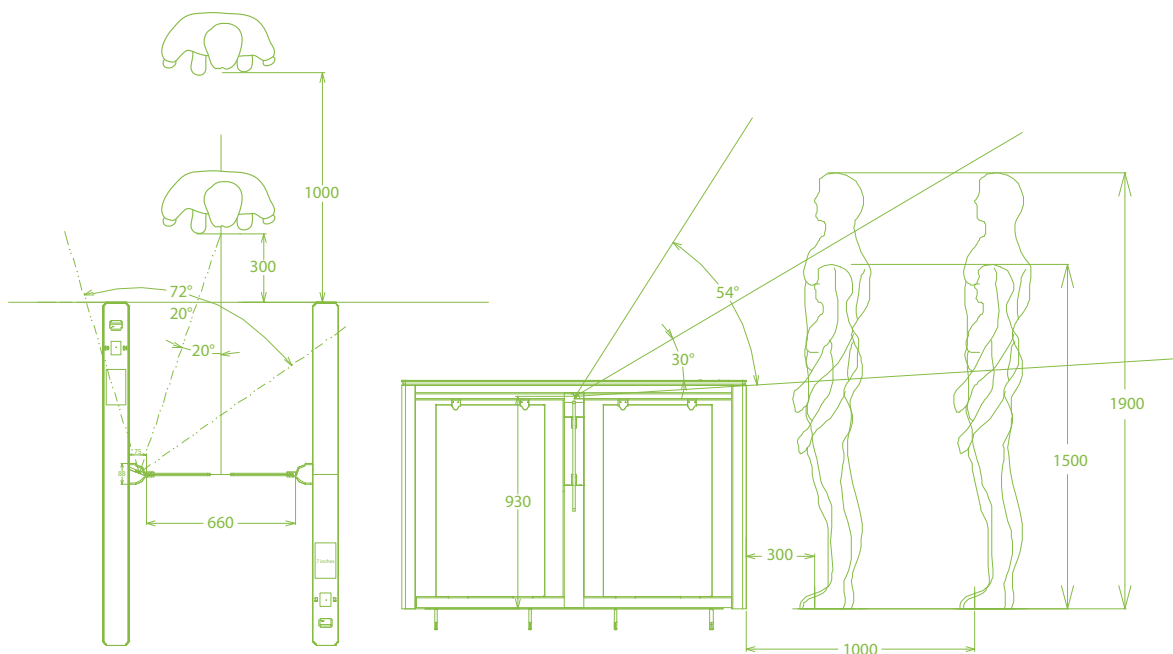

Facial Recognition Camera angle and distance

(mm)

Model	Comet-S1000	Comet-S1200
Audio Indicator	Internal Buzzer	
Visual Indicator	LED strip along the lid (7 Colour RGB, Customizable) blue= stand by steady green=normal use steady Red= door closing flashing red= alarm	
Display	1 or 2*7" IPS touch monitor (under mount facial recognition version only)	
Lane Type	Single Lane	Dual-wings (with Comet-S1000 only)
Lane width	660mm (Standrad) 900mm (Optional)	
Barrier Movement Type	Swing	
Motor	DC brushless motor	
Movement Speed	0.8s Per movement (open/close timing)	
Movement Accuracy	≤1.5 Degree per movement	
Clutch	Mechanical clutch for anti-panic /anti-collision	
Lid Material	Tempered glass (black) (standard)	
Lid Options Authentication Methods	Streamlined under mount options: fingerprint / RFID / QR Code / fingerprint + RFID / fingerprint + QR Code / fingerprint + RFID +QR Code / facial recognition with display Top mount option: mounting pole (compatible with ProFace X / SpeedFace V5L / Elite Pass)	
Chassis Material	Cast aluminium alloy (T=3mm)	
Chassis Colour	Silver (Standard), gold (Optional)	
Door Leaf Material (H*W)	Clear acrylic (630*295mm)(standard) Clear tempered glass (630*295mm)	
IR Sensors	8 pairs (Standard) (High position)	
Motherboard Function	System configuration, access mode configuration, anti-pinch configuration, anti-tailgate configuration etc.	
Motherboard Communication	Fire alarm Port(Relay)*1, RS485 Port*1,	
Controller	PGIC controller (Optional) Others depends on dimensions fitting in (Optional)	
Credential Options	Under mount RFID reader: (support model: ProLD Series, Armatura EP10C & Armatura EP20 Series) under mount QR Code Reader: QR500 under mount fingerprint reader: FR1200 / FR1500 under mount facial recognition terminal: G4 Pro Top mount facial recognition terminal: ProFaceX/ Elite Pass/ SpeedFace V5L	
Flow Rate	RFID: 30 passengers per minute QR Code: 30 passengers per minute Fingerprint: 20passengers per minute Face: 15 passengers per minute	
Accessibility	Under mount facial recognition version: adult, children, disability Rest of the versions: adult, children (with care), disability (with care)	
Power Supply	110V / 220V AC @ 50~60Hz	
Power Rating	20VA (stand by) 120VA (operation)	
Fire Signal	Input for voltage free contact	
Noise Level	Less than 60dB	
MTTR	Less than 60minutes	
MCBF	6 million	

Weight	Gross weight (130kg) Net weight (100kg)	Gross weight (80kg) Net weight (65kg)
Dimension (L*W*H)	1500 * 115 * 1000mm (Standard)	
Dimensions With Packing (L*W*H)	1600 * 160 * 1200mm	
Operating Temperature	-28°C to 60°C	
Operating Humidity	95% RH (non-condensing)	
Certifications	CE, FCC	
Ingress Protection Rating	N/A (waterproof and dustproof) N/A (barrier only) (vandal resistant)	
Supported Software	ZKEasyGo / ZKBio Access / ZKBio CVSecurity (Depends on equipped access controller)	
Safety Features	<ul style="list-style-type: none"> Safety force sensing Lower safety sensors Accurate presence sensing Emitter/ receiver infrared sensors technology Logic voltage 24V DC Voltage free contact input for fire alarm fail state Auto opening on power off Anti-panic push opening in operation Wide walkway for wheelchair or easier access Accompanied wheelchair or child passage management (under mount facial recognition version) 	
Security Features	Anti-intrusion, anti-tailgating, wrong way enter alarm, Automatically close door no one pass	
Product Delivery	Pre-assembled	
Application Environment	Indoor	
Site Preparation	Flat & level finished floor (base plate in options for unfinished floor)	
Security Level	Middle	
Emergency Mode	Support(door unlock automatically)	
Packing Material	Wooden box	

Color Options

	Gold	Silver
Comet-S1000		
Comet-S1200		

Dimensions

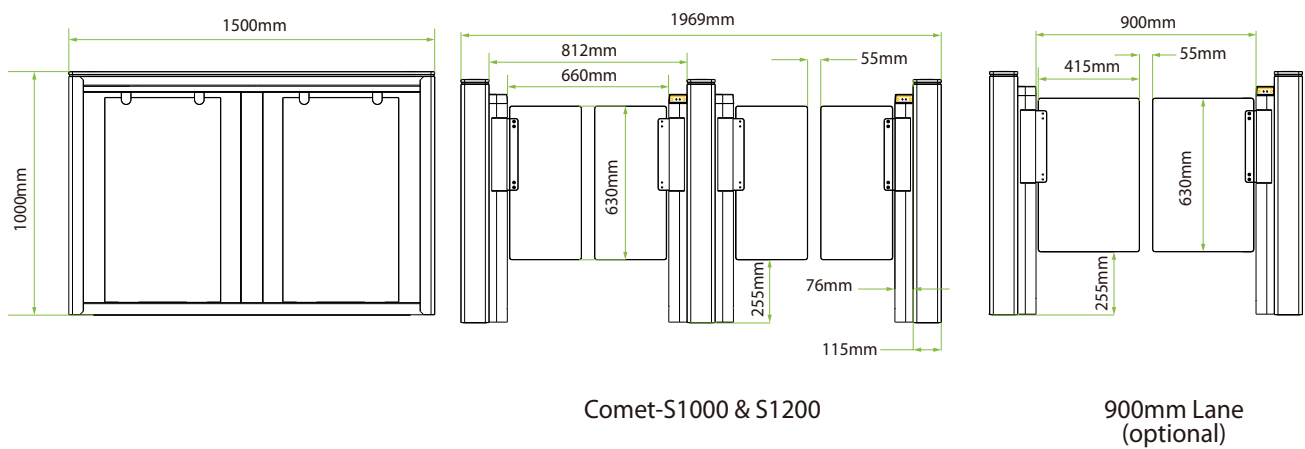
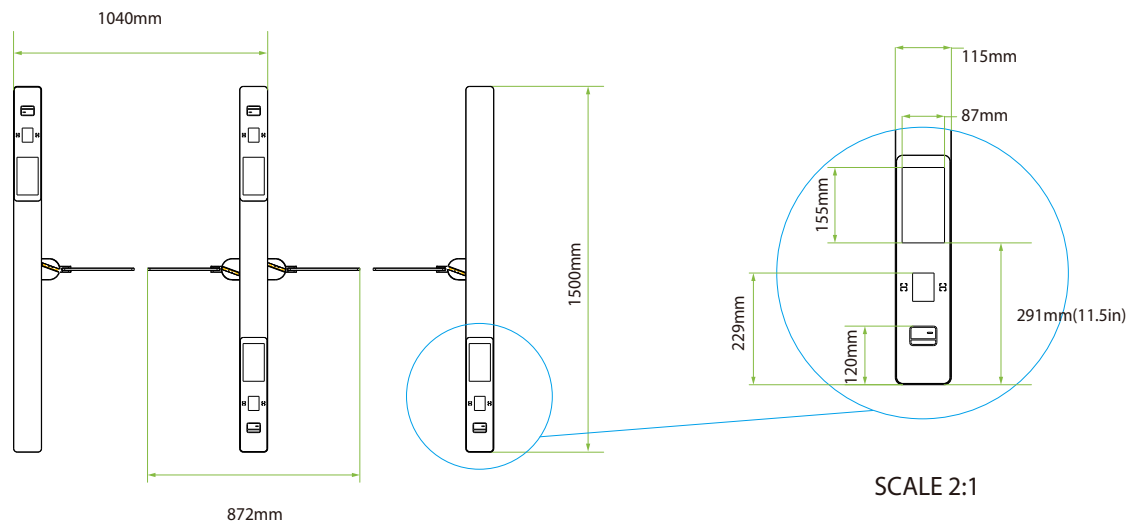

Application Scenarios



Office Building

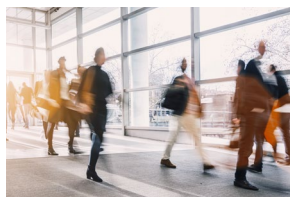

Conference



Hotel



Station



ZKTECO CO.,LTD.

www.zkteco.com

E-mail: sales@zkteco.com



Copyright © 2026 ZKTECO CO., LTD. All rights reserved.

V 4.1 04/24/2026