

User Manual

Mars-F1000 Series

Applicable Models: Mars-F1000/1011/1022/1200/1211/1222

Date: April 2026

Doc Version: 1.2

English

Thank you for choosing our product. Please read the instructions carefully before operation. Follow these instructions to ensure that the product is functioning properly. The images shown in this manual are for illustrative purposes only.



For further details, please visit our Company's website
www.zkteco.com.

Copyright © 2026 ZKTECO CO., LTD. All rights reserved.

Without the prior written consent of ZKTeco, no portion of this manual can be copied or forwarded in any way or form. All parts of this manual belong to ZKTeco and its subsidiaries (hereinafter the "Company" or "ZKTeco").

Trademark

ZKTeco is a registered trademark of ZKTeco. Other trademarks involved in this manual are owned by their respective owners.

Disclaimer

This manual contains information on the operation and maintenance of the ZKTeco equipment. The copyright in all the documents, drawings, etc. in relation to the ZKTeco supplied equipment vests in and is the property of ZKTeco. The contents hereof should not be used or shared by the receiver with any third party without express written permission of ZKTeco.

The contents of this manual must be read as a whole before starting the operation and maintenance of the supplied equipment. If any of the content(s) of the manual seems unclear or incomplete, please contact ZKTeco before starting the operation and maintenance of the said equipment.

It is an essential pre-requisite for the satisfactory operation and maintenance that the operating and maintenance personnel are fully familiar with the design and that the said personnel have received thorough training in operating and maintaining the machine/unit/equipment. It is further essential for the safe operation of the machine/unit/equipment that personnel has read, understood and followed the safety instructions contained in the manual.

In case of any conflict between terms and conditions of this manual and the contract specifications, drawings, instruction sheets or any other contract-related documents, the contract conditions/documents shall prevail. The contract specific conditions/documents shall apply in priority.

ZKTeco offers no warranty, guarantee or representation regarding the completeness of any information contained in this manual or any of the amendments made thereto. ZKTeco does not extend the warranty of any kind, including, without limitation, any warranty of design, merchantability or fitness for a particular purpose.

ZKTeco does not assume responsibility for any errors or omissions in the information or documents which are referenced by or linked to this manual. The entire risk as to the results and performance obtained from using the information is assumed by the user.

ZKTeco in no event shall be liable to the user or any third party for any incidental, consequential, indirect, special, or exemplary damages, including, without limitation, loss of business, loss of profits, business interruption, loss of business information or any pecuniary loss, arising out of, in connection with, or

relating to the use of the information contained in or referenced by this manual, even if ZKTeco has been advised of the possibility of such damages.

This manual and the information contained therein may include technical, other inaccuracies or typographical errors. ZKTeco periodically changes the information herein which will be incorporated into new additions/amendments to the manual. ZKTeco reserves the right to add, delete, amend or modify the information contained in the manual from time to time in the form of circulars, letters, notes, etc. for better operation and safety of the machine/unit/equipment. The said additions or amendments are meant for improvement /better operations of the machine/unit/equipment and such amendments shall not give any right to claim any compensation or damages under any circumstances.

ZKTeco shall in no way be responsible (i) in case the machine/unit/equipment malfunctions due to any non-compliance of the instructions contained in this manual (ii) in case of operation of the machine/unit/equipment beyond the rate limits (iii) in case of operation of the machine and equipment in conditions different from the prescribed conditions of the manual.

The product will be updated from time to time without prior notice. The latest operation procedures and relevant documents are available on <http://www.zkteco.com>

If there is any issue related to the product, please contact us.

ZKTeco Headquarters

Address ZKTeco Industrial Park, No. 32, Industrial Road,
Tangxia Town, Dongguan, China.

Phone +86 769 - 82109991

Fax +86 755 - 89602394

For business-related queries, please write to us at: sales@zkteco.com.

To know more about our global branches, visit www.zkteco.com.

About the Company

ZKTeco is one of the world's largest manufacturer of RFID and Biometric (Fingerprint, Facial, Finger-vein) readers. Product offerings include Access Control readers and panels, Near & Far-range Facial Recognition Cameras, Elevator/floor access controllers, Turnstiles, License Plate Recognition (LPR) gate controllers and Consumer products including battery-operated fingerprint and face-reader Door Locks. Our security solutions are multi-lingual and localized in over 18 different languages. At the ZKTeco state-of-the-art 700,000 square foot ISO9001-certified manufacturing facility, we control manufacturing, product design, component assembly, and logistics/shipping, all under one roof.

The founders of ZKTeco have been determined for independent research and development of biometric verification procedures and the productization of biometric verification SDK, which was initially widely applied in PC security and identity authentication fields. With the continuous enhancement of the development and plenty of market applications, the team has gradually constructed an identity authentication ecosystem and smart security ecosystem, which are based on biometric verification techniques. With years of experience in the industrialization of biometric verifications, ZKTeco was officially established in 2007 and now has been one of the globally leading enterprises in the biometric verification industry owning various patents and being selected as the National High-tech Enterprise for 6 consecutive years. Its products are protected by intellectual property rights.

About the Manual

This manual introduces the operations of **Mars-F1000 Series**.

All figures displayed are for illustration purposes only. Figures in this manual may not be exactly consistent with the actual products.

Features and parameters with ★ are not available in all devices.

Document Conventions

Conventions used in this manual are listed below:

GUI Conventions

For Software	
Convention	Description
Bold font	Used to identify software interface names e.g. OK, Confirm, Cancel.
>	Multi-level menus are separated by these brackets. For example, File > Create > Folder.
For Device	
Convention	Description
<>	Button or key names for devices. For example, press <OK>.
[]	Window names, menu items, data table, and field names are inside square brackets. For example, pop up the [New User] window.
/	Multi-level menus are separated by forwarding slashes. For example, [File/Create/Folder].

Symbols





Convention	Description
	This represents a note that needs to pay more attention to.
	The general information which helps in performing the operations faster.
	The information which is significant.
	Care taken to avoid danger or mistakes.
	The statement or event that warns of something or that serves as a cautionary example.

Table of Contents

1	OVERVIEW	6
1.1	Chassis Design and Dimensions	6
1.2	Mechanical System	7
1.3	Electronic Control System	7
1.4	Working Principle.....	8
1.5	System Composition	8
1.6	Technical Specifications.....	9
1.7	Anti-collision Force Parameters.....	10
2	FUNCTION INTRODUCTION	11
2.1	Fingerprint Verification.....	11
2.2	Card Verification	12
2.3	QR code Verification	13
2.4	Facial Verification★	14
2.5	Wireless Remote Control★	16
3	MENU INTRODUCTION	17
4	WIRING DIAGRAM	27
5	PACKING LIST	28
6	MAINTENANCE	29
6.1	Chassis Maintenance	29
6.2	Movement Maintenance.....	29
6.3	Power Supply Maintenance	29
7	TROUBLESHOOTING	30

1 Overview

The Mars-F1000 Series flap barrier is an elegant cost-effective entrance control system designed for high-traffic volume. The Mars-F1000 Series Flap Barrier are normally held in a locked position, thus denying access to the secured side. When the Mars-F1000 Series correctly identifies the user's Card (RFID)/Fingerprint/QR code, etc. to verify the identity, and the barrier opens to allow the pedestrians to pass by.



1.1 Chassis Design and Dimensions

The device has a stainless steel (Mars series) and cold rolled steel (Mars Pro series) plate stamp form that makes it anti-rust and durable. The Acrylic panel provides simple and beautiful design with corrosion protection. It provides orderly and civilized passage to the persons and restricts illegal personnel access. In case of emergencies, it ensures that evacuation passage runs smoothly and is convenient for personnel.

Mars-F1000's appearance and dimensions are shown below:

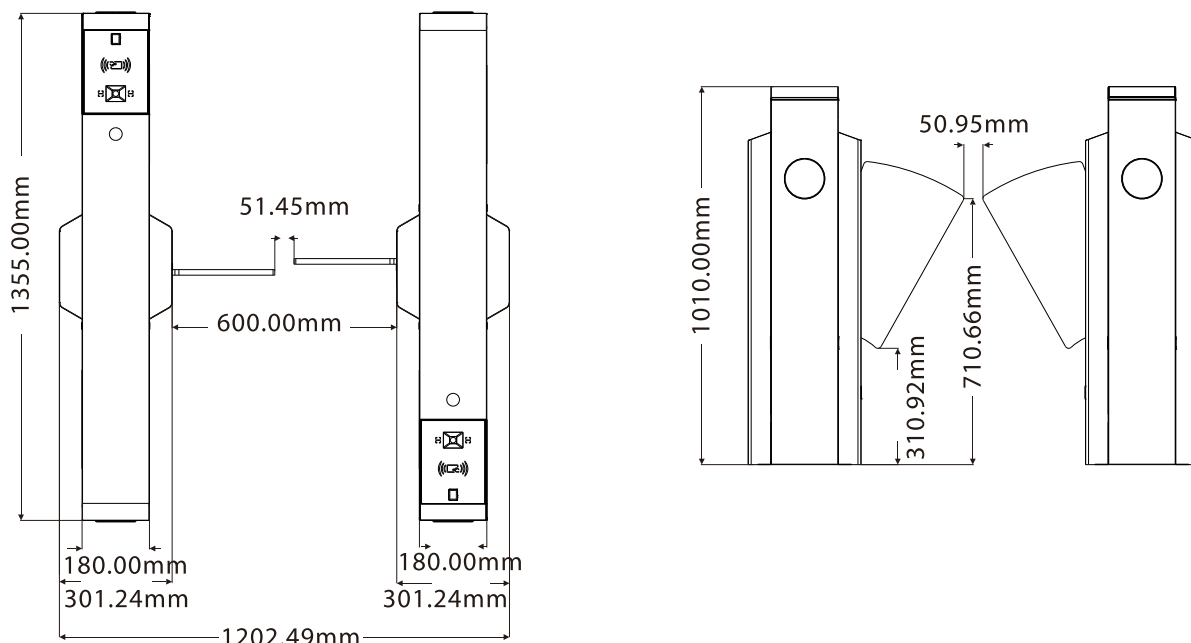

1.2 Mechanical System

The mechanical system of the flap barrier includes the chassis and the core component. The chassis is a carrier where the Direction indicator, Reader, QR code scanner, Fingerprint sensor, Infrared sensor, and the Door lock are installed. The core component mainly consists of the Motor, Frame, Bearing, and swing Arm.

1.3 Electronic Control System

The electronic control system of a flap barrier is mainly composed of the Card Reader/Fingerprint sensor/QR code, Flap Barrier control board, Infrared Sensor, Direction Indicator and Alarm.

Reader: The reader reads the data in the card and sends it to the Access Controller.

Fingerprint sensor: The device compares the fingerprint that is being pressed onto the fingerprint sensor with all the fingerprint data and sends it to the Access Controller.

QR code sensor: The sensor compares the acquired QR code with all QR code data registered in the device and sends it to the Access Controller.

Flap barrier control board: The flap barrier control board is the system's control center that receives signals from the reader and the photoelectric switch performs logical calculation and processing of these signals and sends executive commands to the Direction indicator, electric motor and the alarm.

Infrared Sensor: It detects the position of the pedestrian and plays the role of safety protection.

Direction Indicator: This indicator displays the pedestrian passage path and directs them to pass through the lane in a safe and orderly manner.

Alarm: The alarm gives an alarm voice if the system detects any unauthorized entry to the passage.

1.4 Working Principle

1. After powering on to the device, the system performs the Power-On Self-Test.
2. When a valid Card/Fingerprint/QR code is detected, the buzzer will give a positive audible prompt to the pedestrian, indicating that successfully verified. And then, the reader sends signals to the Access Controller to request permission to pass through the passage. The Access Controller will send the signal to the master control panel.
3. After receiving the signal from the Access Controller, the flap barrier control board sends valid control signals to the direction indicator and the electric motor. At last the direction arrow turns green.
4. Pedestrians passes through the passage according to the direction indicator signs. Infrared sensors keep on detecting the pedestrian during the whole process, and continue to send signal to the master control board until the pedestrian passes completely through the passage.
5. If the pedestrian enters the passage but forgets to verify identification, or if the card held/fingerprint/QR code by the pedestrian is invalid, the system will prompt an audible alarm to stop and retreat the pedestrian from the passage. The pedestrian can pass through the passage only after a valid card/fingerprint/QR code is successfully verified.

1.5 System Composition

The single-lane management system is composed of two single-core swing barriers. The multi-lane management system is composed of two single-core barriers and multiple dual-core barriers.

Working modes of the system

To make the product more versatile, this system provides multiple working modes for the user, including Normal working mode, Normally open mode, Normally close mode and Testing mode.

Normal Working Mode: In this working mode, the flap barrier works normally.

Normal Open Mode: In this working mode, the flap barrier is always open.

Normal Close Mode: In this working mode, the flap barrier is always closed.

Testing Mode: In this working mode, the flap barrier performs auto-test.

1.6 Technical Specifications

Feature	Specification
Communication	TCP/IP, RS485, 4G/WIFI
Input Voltage	AC110V to 220V, 50 Hz to 60Hz
Input Control Signal	Switching Signal
Output Voltage	DC 24V
Protection Level	IP34
Time of Gate Opening/Closing	Minimum 0.8 Seconds
Relative Humidity	<95% (Non-condensing)
Temperature	-25°C to 65°C (Standard) -40°C to 80°C (Optional)
Throughput Rate	Maximum 30 persons/minute
Motor	Brushless Motor
Infrared Sensors	5 pairs (option: ≤ 12 pairs)
Working Environment	Indoor/Outdoor (if sheltered)
Dimension(mm) (L*W*H)	1355* 180*1010
Noise	<60dB
Certifications	CE, FCC

1.7 Anti-collision Force Parameters

The swing arm can withstand shaking of 400N.

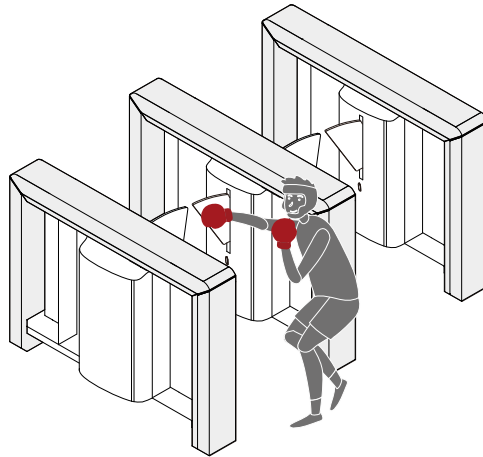

 The picture only shows the anti-collision level, please do not damage the device.

2 Function Introduction

2.1 Fingerprint Verification

In this verification mode, the device compares the fingerprint that is being pressed onto the fingerprint reader with all the fingerprint data sends it to the Access Controller.

The device enters the fingerprint authentication mode when a user presses his/her finger onto the fingerprint scanner.

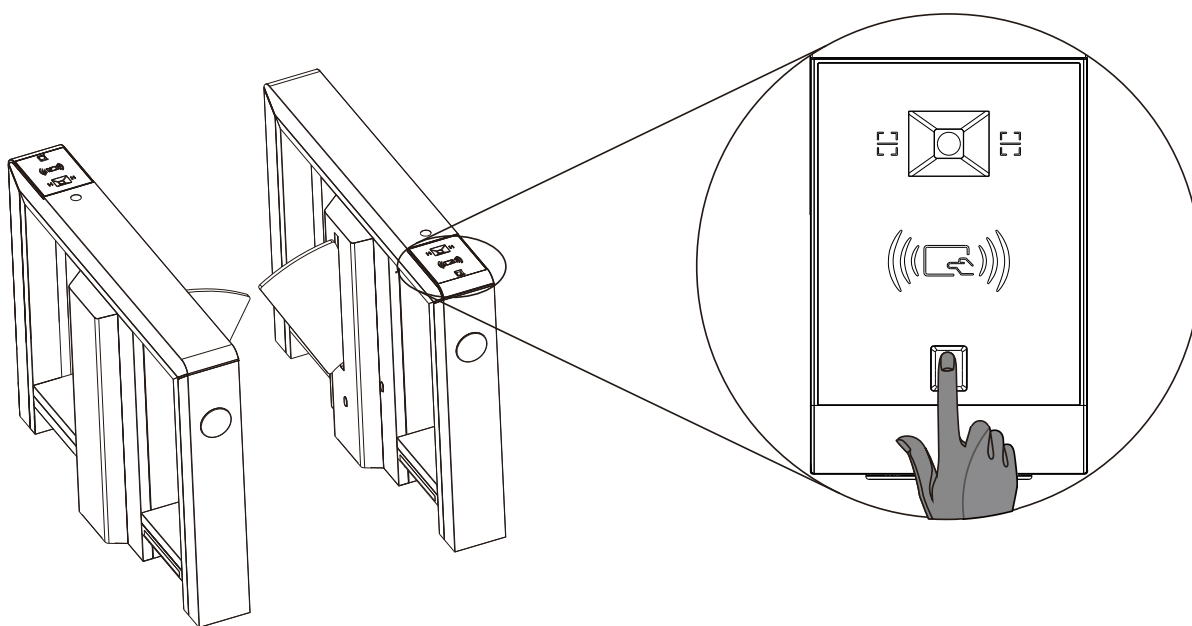

Recommended fingers: It is recommended to use index, middle, or ring finger for registration and avoid using the thumb or little finger, as they are difficult to accurately press onto the fingerprint reader.

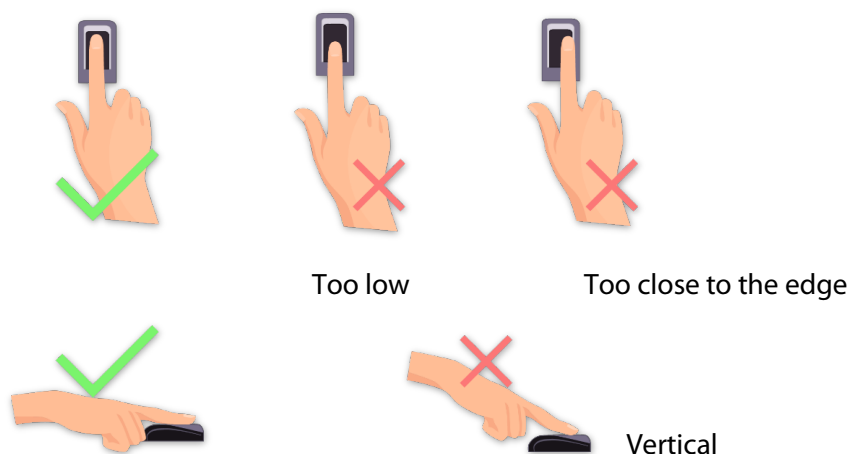

Note: Please use the correct method when pressing your fingers onto the fingerprint reader for registration and identification. Our company will assume no liability for recognition issues that may result from incorrect usage of the product. We reserve the right of final interpretation and modification concerning this point.

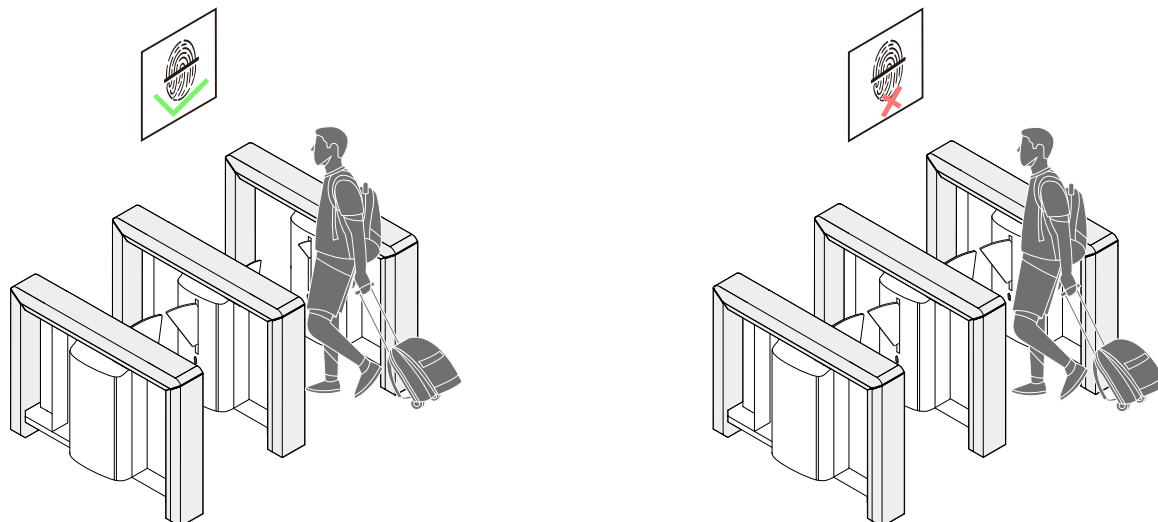

2.2 Card Verification

The Card Verification mode compares the card number in the card induction area with all the card number data registered in the device and sends it to the Access Controller.

The device enters the card authentication mode when a user presses his/her card to the card reading area.

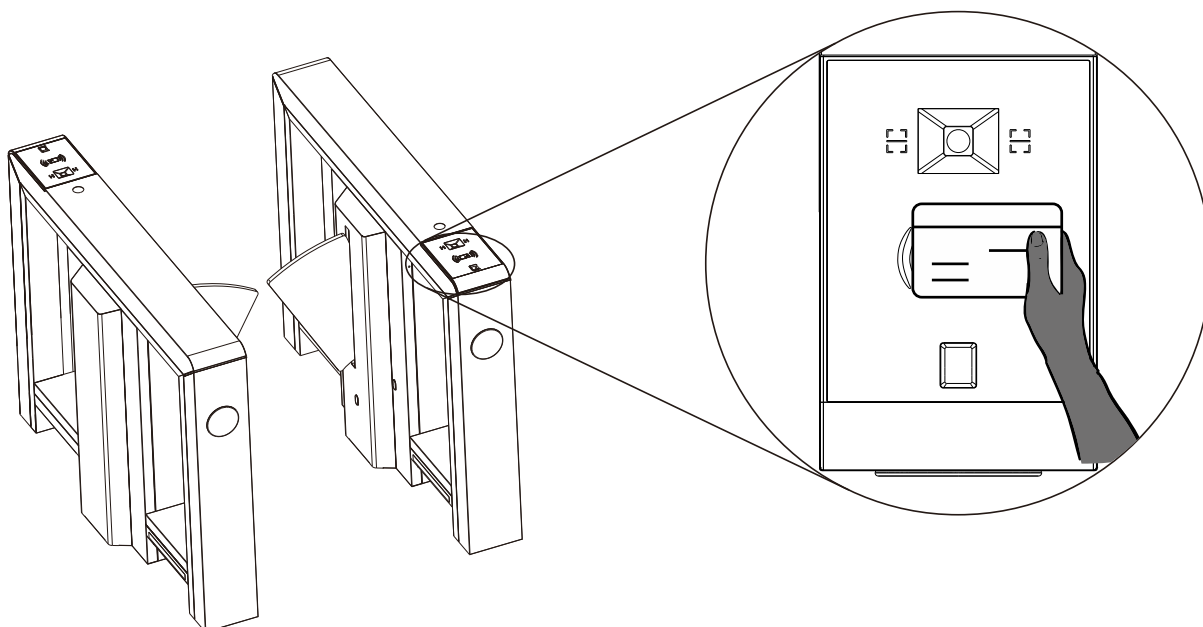

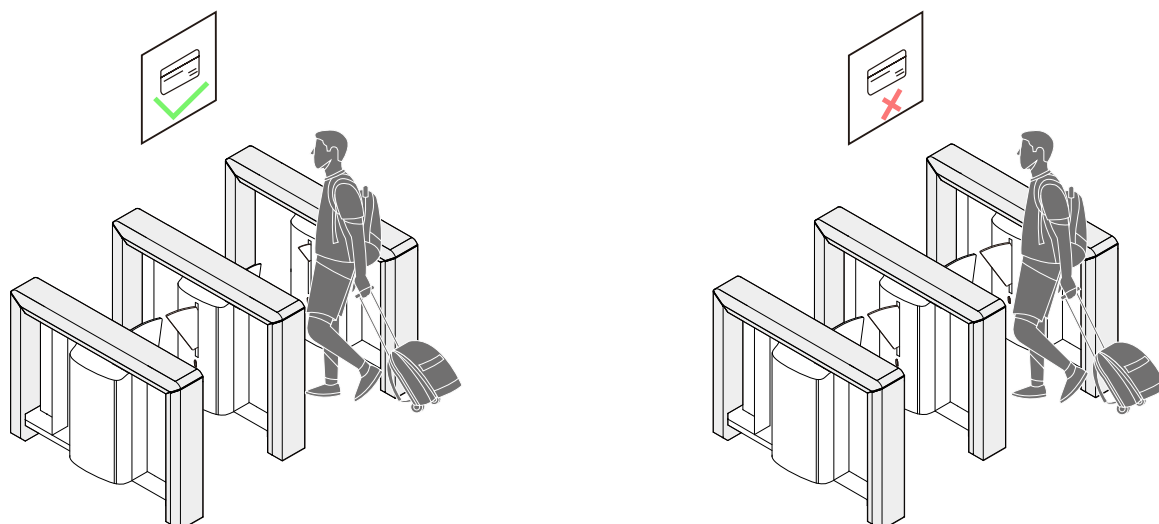

2.3 QR code Verification

The QR code Verification mode is to scan the QR code on the user's mobile phone through the QR code scanner and compare the data with the registered QR code, and then sends it to the Access Controller.

When the user places the mobile phone displaying with the QR code on top of the QR code scanner, the device enters the QR code authentication mode.

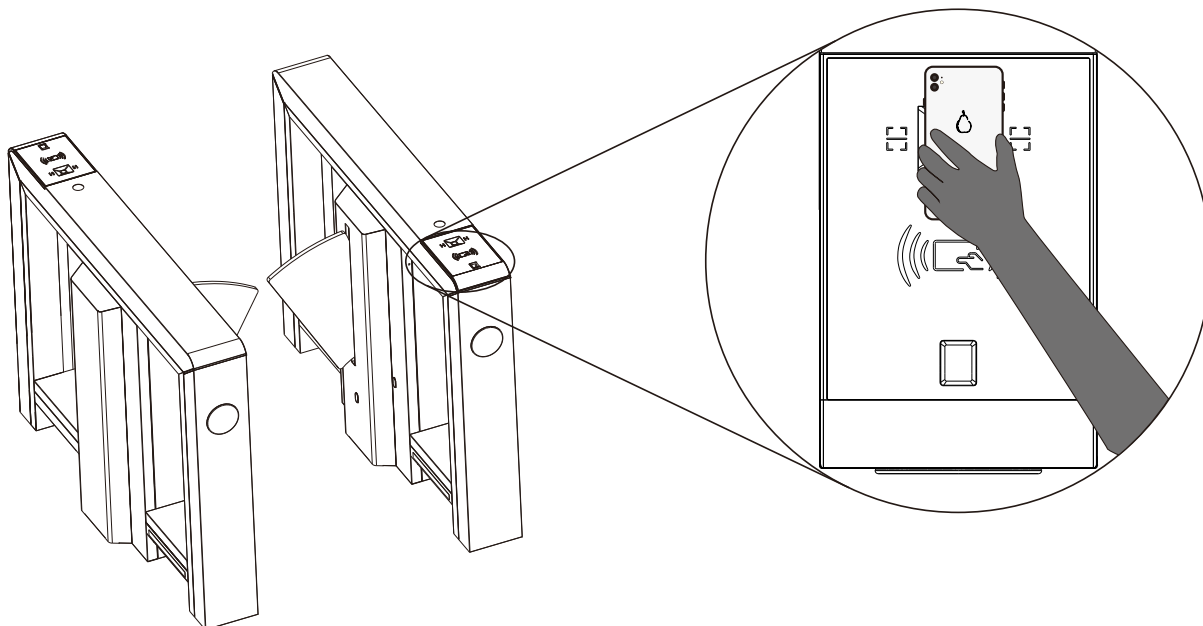

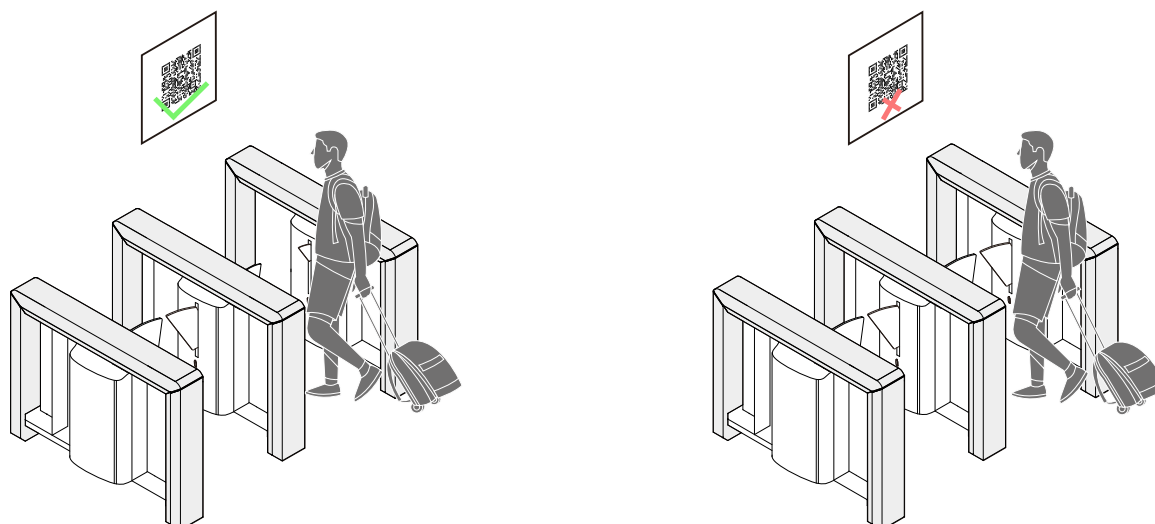

2.4 Facial Verification★

In this verification mode, the device compares the collected facial images with all face data registered in the device and then sends it to the Access Controller.

Try to keep the face in the centre of the screen during authentication. Please face towards the camera and stay still during face registration.

Recommended Standing Posture and Facial Expression:



Note: Please keep your facial expression and standing posture natural while enrollment or verification.

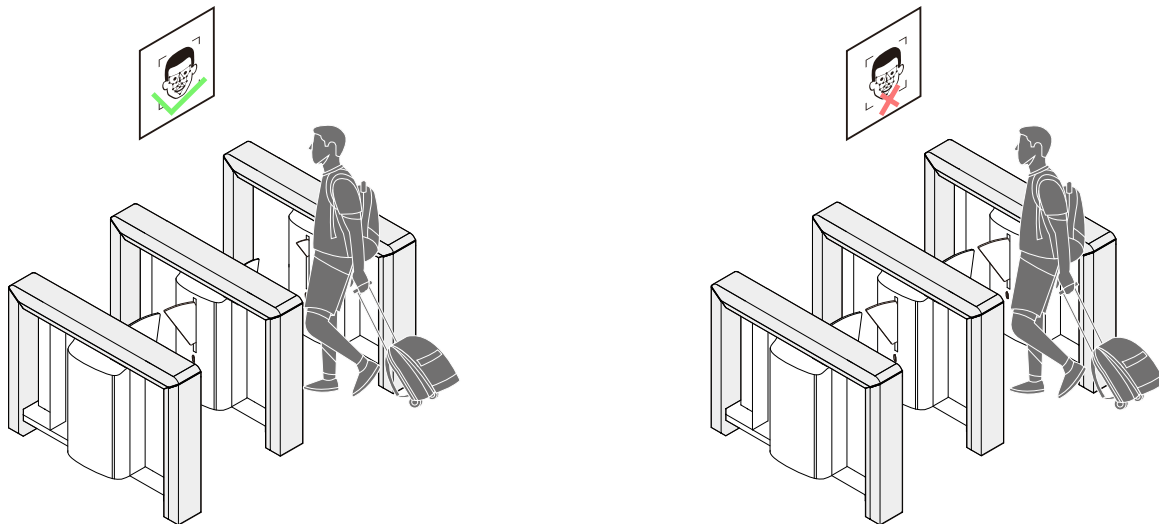

Installation on the barrier gate:

1. Please pass the wire through the bracket before installation.
2. Insert the bracket into the hole and fix it with a nut.
3. Adjust the angle of the device.

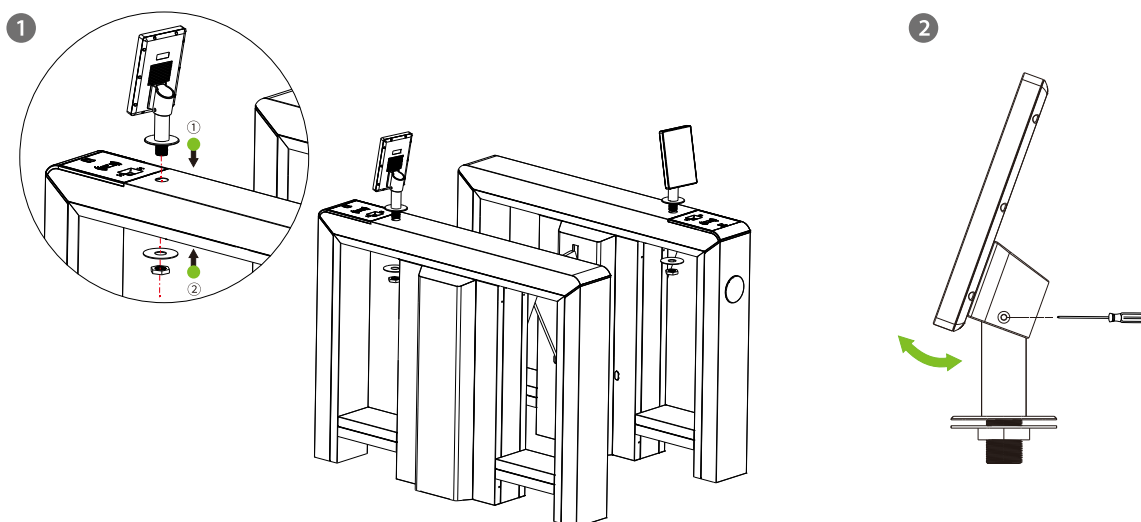

2.5 Wireless Remote Control★

The wireless remote control of flap barrier is an intelligent device that remote controls the entrance and exit. It is designed for manual control of the flap barrier by the administrator. The wireless remote control has four buttons A, B, C, and D, corresponding to the options open entrance gate, open exit gate, emergency mode open-bar pass, and alarm lock.

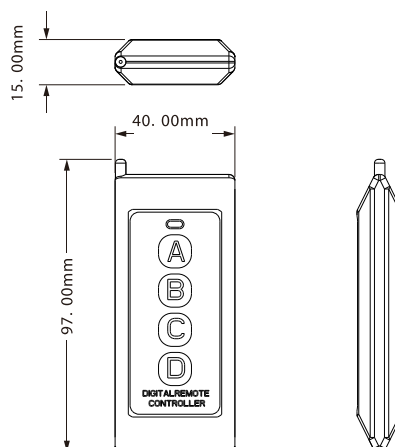

Buttons	Description
A	Press the button once to open the flap barrier on the entrance and can pass by verification from the entrance.
B	Press the button once to open the flap barrier on the exit and can pass by verification from the exit.
C	In emergency mode, press the button once to open the gate. Then the entrance and exit sides gate open and can pass freely without verification.
D	Press the button once to close the gate. Then the entrance and exit sides are controlled by the flap barrier. The verification becomes invalid, and no pass is allowed.

3 Menu Introduction

There are 4 keys on the control panel, "MENU", "MODE", "ADD" and "DEC".

MENU: It is used for enter the Settings menu and to confirm the current modified value.

MODE: It is used to go back to the previous menu and discard the current operation.

ADD: It is used for navigating to the upper menu item and increasing the value.

DEC: It is used for navigating to the lower menu item and decreasing the value.

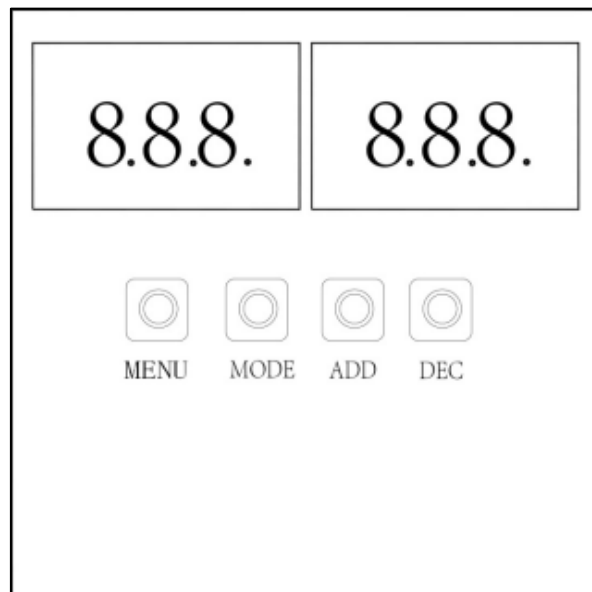

Display Mode (01EXXX)

- (01E000) Displays current position of the gate.
- (01E001) Infrared input signal.
- (01E002) Controls input signal.
- (01E003) Test mode.
- (01E004) Version number. (Default)

Opening Mode Setting (02EXXX)

- (02E001) Two-way controlled, both need verification (Default)

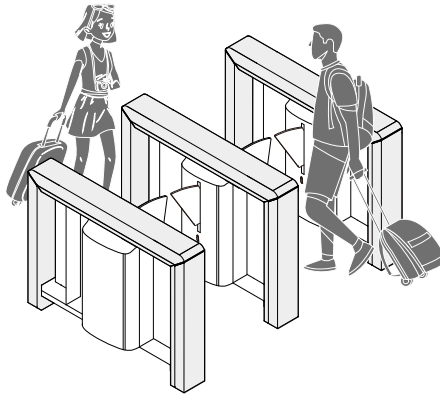

- (02E002) In need verification, out free

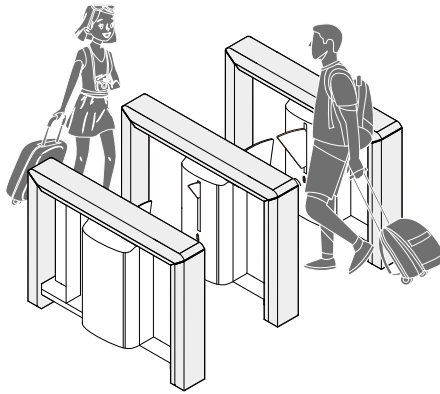

- (02E003) In free, out need verification

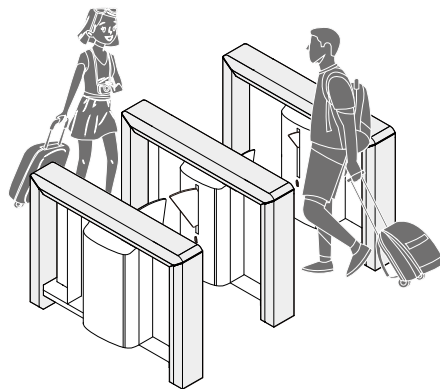

- (02E004) Two-way free

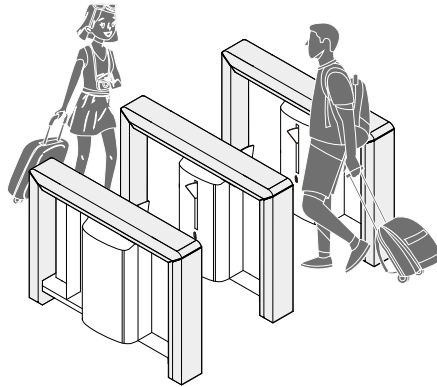

- (02E005) In need verification, out prohibited

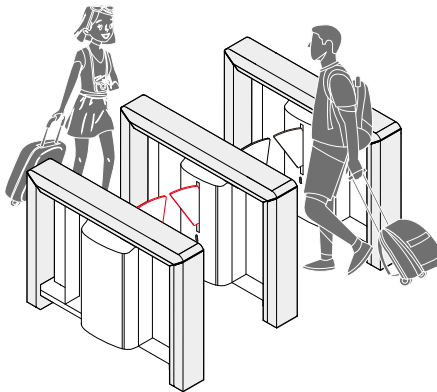

- (02E006) In prohibited, out need verification

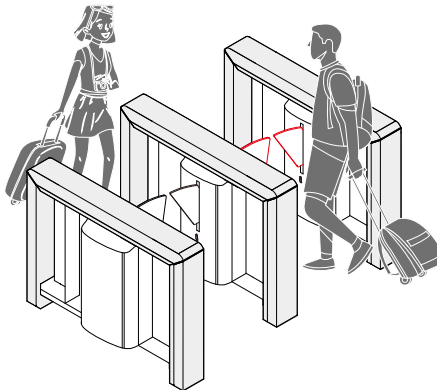

- (02E007) In free, out prohibited

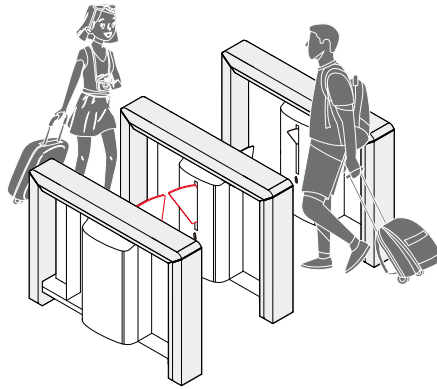

- (02E008) In prohibited, out free

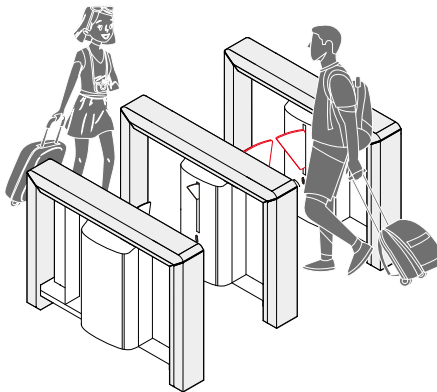

- (02E009) Two-way prohibited

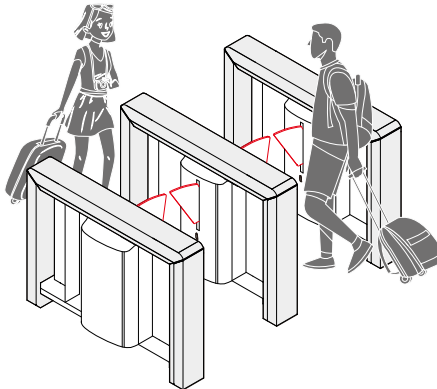

- (02E010) Two-way normally open



Gate Opening Speed (03EXXX)

Set the gate opening speed to open the gate. The larger the number is set, the faster the speed. The Gate Opening Speed value can be set between 5 to 32 and the default value is 22.

Gate Opening Deceleration Distance (04EXXX)

The larger the number, the longer the deceleration time and the more stable the barrier operation. The Gate Opening Deceleration Distance can be set between 0 to 50 and the default value is 22.

Gate Opening Compensation Speed (05EXXX)

It can be set when the barrier cannot open to the limit or shakes. The larger the number is set, the faster of the compensation speed. The Gate Opening compensation Speed value can be set between 0 to 50 and the default value is 18.

Gate Closing Speed (06EXXX)

Set the gate closing speed to close the gate. The larger the number is set, the faster the speed. The Gate Closing Speed value can be set between 5 to 32 and the default value is 22.

Gate Closing Deceleration Distance (07EXXX)

The larger the number, the longer the deceleration time and the more stable the barrier operation. The Gate Closing Deceleration Distance value can be set between 0 to 50 and the default value is 22.

Gate Closing Compensation Speed (08EXXX)

It can be set when the barrier cannot close to the zero position or shakes. The larger the number is set, the faster of the compensation speed. The Gate Closing compensation Speed value can be set between 0 to 50 and the default value is 18.

Master/Slave Setting (09EXXX)

- (09E000) Master
- (09E001) Slave

(When resetting to factory settings, the value remains unchanged.)

RS485 Address (10EXXX)

It can be set between 0 to 254 and the default value is 0.

Open Duration Time (11EXXX)

It can be set the valid time period after successful verification, after arriving at the set time, the gate will close automatically, the larger the number set, the longer the valid time. The valid value is 2 to 60 seconds, and the default value is 5s.

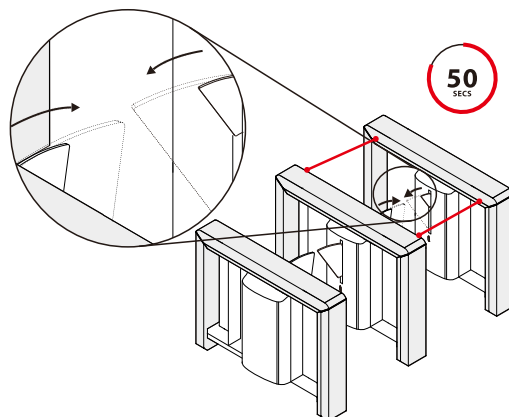

Gate Closing Delay Time (12EXXX)

Set the delay time of gate closing after passing. The valid value for gate closing delay time can be set between 0 to 60s and the default value is 0s.

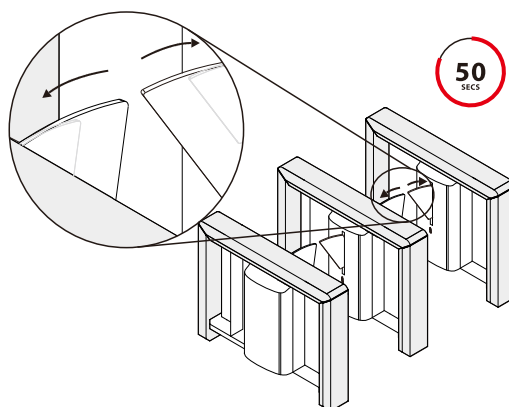

Gate Opening Memory (14EXXX)

- (14E000) Close (Default)
- (14E001) Open

When more than two legal access signals are given at the same time (including the same direction and the opposite direction), the system will remember all pass requests and complete each pass in turn.

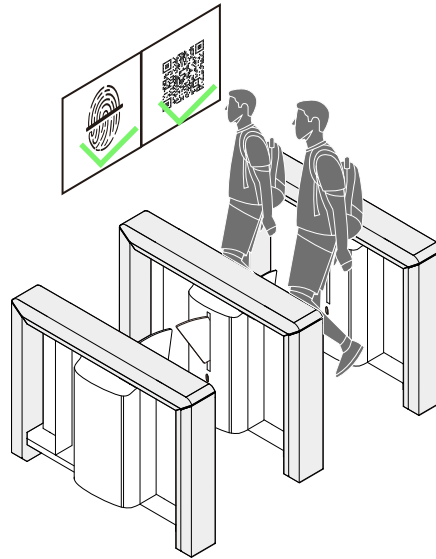

Authentication in Lane (15EXXX)

It allows the pedestrian verification during IR sensor triggered.

- (15E000) Allow (Default)
- (15E001) Forbidden

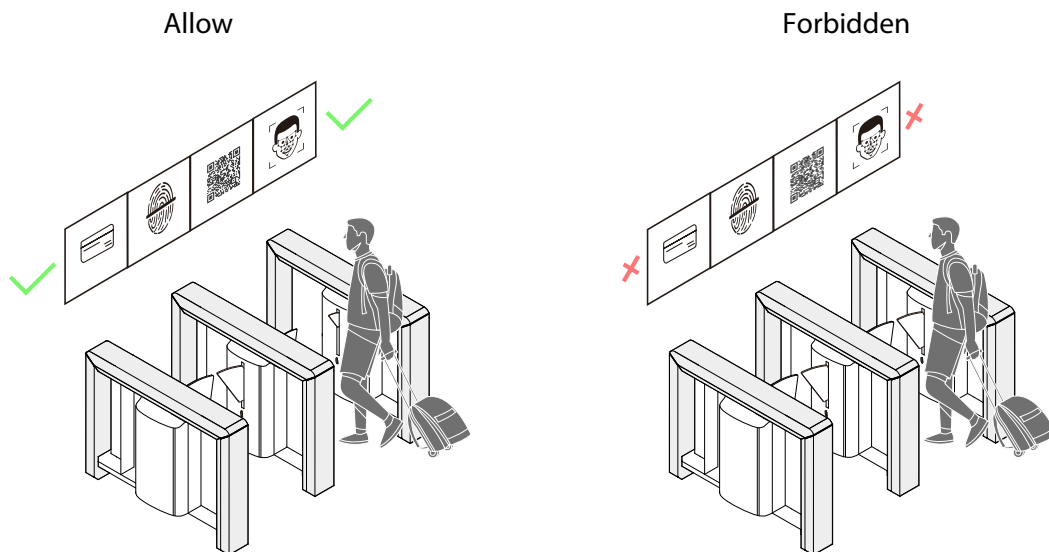

Volume Setting (16EXXX)

Volume Setting is used for adjusting the volume of the device. The larger the number is set, the louder the volume. The valid value for Volume Setting can be set between 1 to 100 and the default value is 70.



Close Alarm Tone (17EXXX)

When the alarm tone is turned off, the Turnstile will not emit an alarm tone when encountering an alarm situation. The following figure shows an example of the prohibition of authentication in lane:

- (17E000) Close
- (17E001) Open (Default)

Number of Pairs of Infrared Sensors (18EXXX)

The valid value is 1 to 8 pairs. If the number is greater than 8, the digital LED displays 18E022.

(When resetting to factory settings, the value remains unchanged.)

Stay Duration Time (19EXXX)

Set the duration of stay in the channel after successful verification. The valid value for Stay Duration Time can be set between 5 to 30 seconds and the default value is 10s.

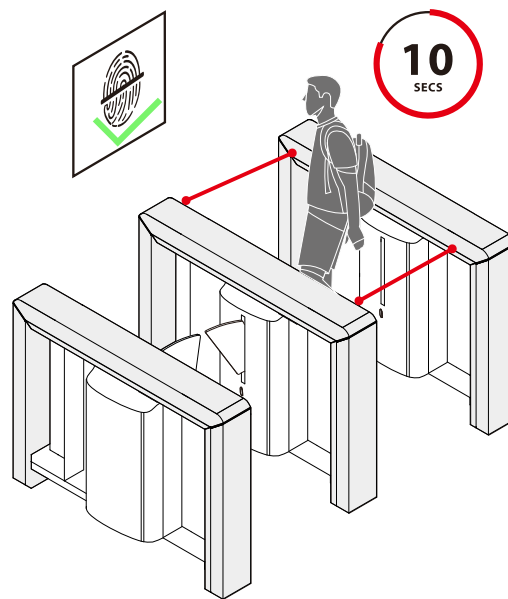

Force Adjustment (20EXXX)

The larger the number, the greater the efficiency of the gate opening and closing force. The valid value for Force Adjustment can be set between 10 to 100 and the default value is 40.

Fire Opening Direction (21EXXX)

According to the external fire device, select the corresponding type of trigger mode.

- (21E000) In open (Default)
- (21E001) Out open

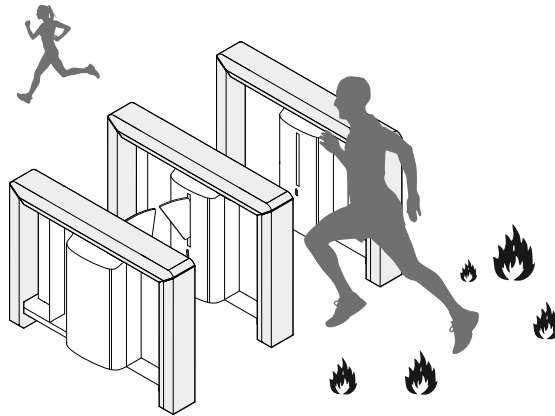

Restore Factory Setting (24EXXX)

- (24E001) Restore factory settings
- (24E002) Restart

Anti-pinch Area Setting (25EXXX)

- (25E000) All Infrared anti-pinch (Default)
- (25E001) First and last pair are not anti-pinch.

False Direction Entry (26EXXX)

When the Anti-pinch Area Setting needs to be set to (25E001) only, the False Direction Entry (26E000) is effective.

- (26E000) Close
- (26E001) Only alarm (Default)
- (26E002) No detection

Close

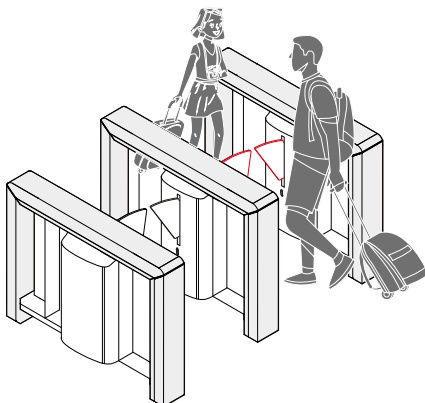

Alarm

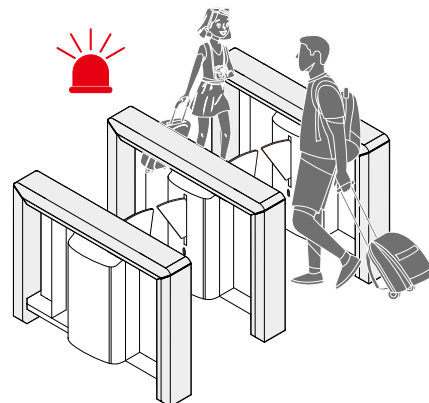

Anti-tailgate Setting (27EXXX)

When the Anti-pinch Area Setting needs to be set to (25E001) only, the Anti-tailgate Setting (27E000) is effective.

- (27E000) Close
- (27E001) Only alarm (Default)
- (27E002) No detection

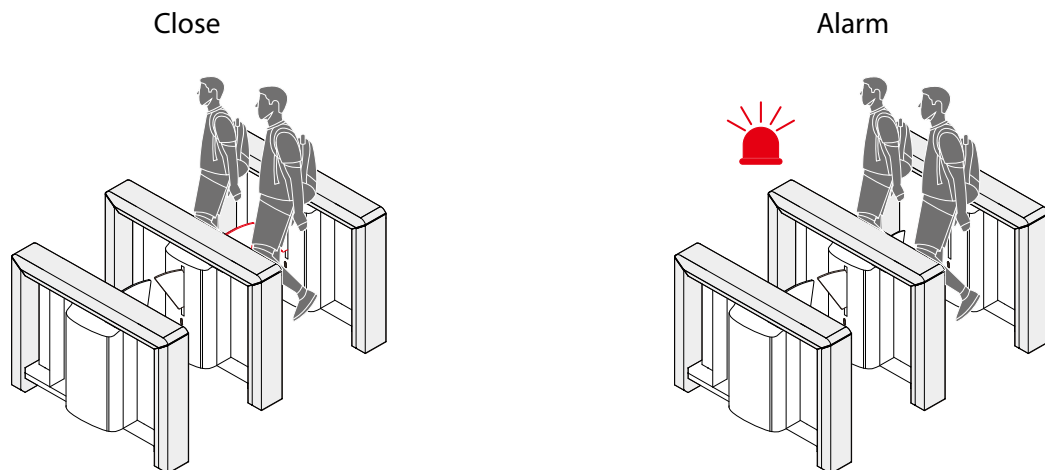

Gate Closing Position (28EXXX)

When the Anti-pinch Area Setting needs to be set to (25E001) only, the Gate Closing Position (28E001) is effective.





- (28E000) Last pair (Default)
- (28E001) Penultimate pair

Anti-pinch Action Setting (29EXXX)

- (29E000) Stop
- (29E001) Open (Default)
- (29E002) Close the function

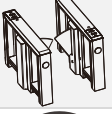
5 Packing List

The package consists of the following items:

	Mars-F1000	1 (master and slave)
	Power cable	1
	Card	1
	Expansion Screw M12*100	8

6 Maintenance

6.1 Chassis Maintenance

The chassis is made up of stainless steel or cold rolled. If it is used for substantial period, then there may be rust stains on its surface. Regularly clean the surface with a clean cloth carefully. Coat the surface with anti-rust oil and do not cover the infrared sensor.

6.2 Movement Maintenance

Switch off the power supply before maintenance. Open the door, clean surface dust, and apply lubricant for smooth movement.

6.3 Power Supply Maintenance

- Switch off the power supply before maintenance.
- Check the power plug connection, if found loose, fix it properly.
- Do not change any connection position randomly.
- Check the external power supply insulation periodically.
- Do periodic check for any kind of leakage.
- Check if the technical parameters of interface are normal.
- Check the service life of the electronic components and replace accordingly.

Caution: All the above-mentioned maintenance methods for swing barrier must be carried out by a professional technician, especially the movement and the electric control part. For ensuring operational safety, first switch off the power supply when the barrier is not in use.

7 Troubleshooting

No.	Failure Description	Cause and Solution
1	No response from direction indicator or indication is not correct.	<p>Cause: It may be due to the incorrect connection of indicator.</p> <p>Solution: Check whether the connection of the indicator is correct or not.</p>
2	After swiping the card, there exists only swing arm action.	<p>Cause: It may be due to the existing any problem in the master and slave machine type setting.</p> <p>Solution: Check the master and slave machine type setting and the 5-core, 2-core connection line.</p>
3	Delay in barrier opening or it doesn't close.	<p>Cause: It may be due to the time of the barrier opening is set as too long.</p> <p>Solution: Check whether the time of the opening is too long, or the IR sensor is covered.</p>
4	Motor doesn't rotate, the resistance is much, or the bearing is loose.	<p>Cause: It may be due to the motor's rotation angle is not set properly.</p> <p>Solution: The motor works properly, but the rotated angle is not sufficient, so it may cause loosening of bearing.</p>
5	When powered ON, the swing doesn't return to the initial position.	<p>Cause: It may be due to the obstacle that lies in the sensing area.</p> <p>Solution: Ensure that no obstacle is in the sensing area, then restart the equipment.</p>

Revision History

Revision	Date	Author	Reviewer	Description
V1.0	02/14/2022	Native Yang		Original Document
V1.2	04/15/2026	Stella Xia		Firmware change of mainboard

ZKTeco Industrial Park, No. 32, Industrial Road,

Tangxia Town, Dongguan, China.

Phone : +86 769 - 82109991

Fax : +86 755 - 89602394

www.zkteco.com

