

Installation Guide

Saturn-H1300

Version: 1.0

Revision History

Revision	Date	Author	Reviewer	Description
V1.0	05/21/2026	Stella Xia		Original Document.

1 Installation Requirements

1. It is recommended that the device be installed on a level and solid floor. If the floor is uneven or not strong enough to hold the device in place, resurface the floor or use a pedestal mount to alleviate the change problem.
2. Do not use the device outdoors or in wet, corrosive conditions to prevent damage from rain, moisture, or chemical materials. Only use it if the device is specifically rated as waterproof.
3. Make sure the device's grounding wire is securely connected. Differentiate between high and low voltage power setups to prevent potential harm to personal safety and unexpected incidents.
4. After installation, check the grounding wire, connectors, junctions of the connecting line, and moving parts to ensure they are securely connected. Promptly tighten any loose nuts, screws, or fasteners to prevent long-term gate failure.

2 Installation

Component List



Left Side Welded Fence Assembly (Qty 1)



Right Side Welded Fence Assembly (Qty 1)



Center Welded Fence Assembly (Qty 1)



38-Bar Fence Assembly (Qty 6)



Fence Bottom Beam (Qty 1)



Fence Top Beam (Qty 1)



Authentication Box (Qty 2)



Square Shaft with 9-Bar Rotor Assembly (Qty 3)



Shaft End Cap (Qty 1)

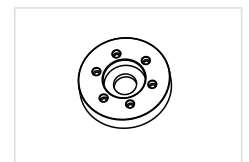

Shaft Bottom Sleeve (Qty 1)

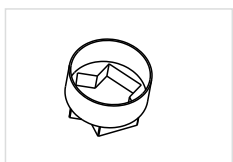

Shaft Guard (Qty 1)



Tapered Roller Bearing for Shaft (Qty 1)



Square Tube Right Angle Bracket for Fence Frame (Qty 1)



Shaft Base (Qty 1)

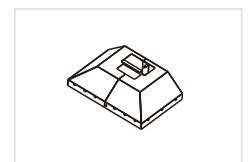

Base Box (Qty 1)

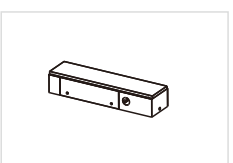

Mechanism Housing (Qty 1)

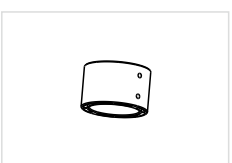

Mechanism Shaft Sleeve (Qty 1)

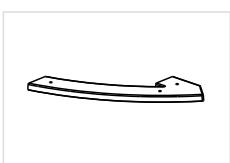

Left Fence Guard (Qty 1)

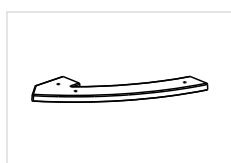

Right Fence Guard (Qty 1)

Accessory List



Socket Head Cap Screw
M8x25mm
(Qty 12)



Socket Head Cap Screw
M5x12mm
(Qty 8)

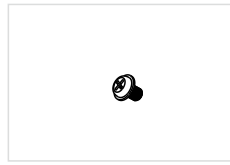

Pan Head Screw
with Washer
M4x6mm
(Qty 4)



Shaft Fixing Block
(Qty 2)



Lock Nut (M5)
(Qty 6)



Hole Plug
(Qty 12)



Socket Head Cap Screw
M6x20mm
(Qty 12)



Spring Washer
M6xT1.6mm
(Qty 12)



Internal Expansion Anchor
100x16xM12mm
(Qty 11)



Ground Silicone
Bumper
(Qty 4)



Flat Head Phillips Screw
M3x6
(Qty 3)



Socket Head Cap Screw
M10x60mm
(Qty 4)



Socket Head Cap Screw
M10x30mm
(Qty 4)

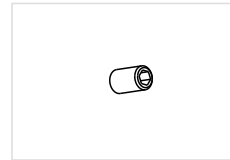

Hex Socket Flat Point
Set Screw
M6x10
(Qty 2)

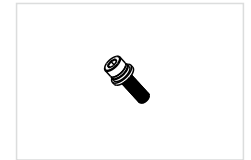

Socket Head Cap Screw
M6x16mm
(Qty 6)



T-Handle Ratchet Wrench
(Qty 1)



Magnetic Bit Holder
(Qty 1)



Maintenance Manual
(Qty 1)



Keys
(Qty 2)

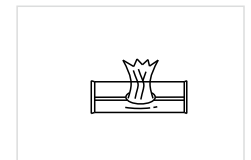

Stainless Steel
Cleaning Wipes
(Qty 2)

Installation Procedure

Step 1: Assemble the Main Fence Frame

Assemble the left, right side and center welded fence assemblies and six 38-bar fence assemblies with the fence top and bottom beams.

Secure them using twenty-four M8x25mm socket head cap screws.

Ensure all connections are tightened securely.

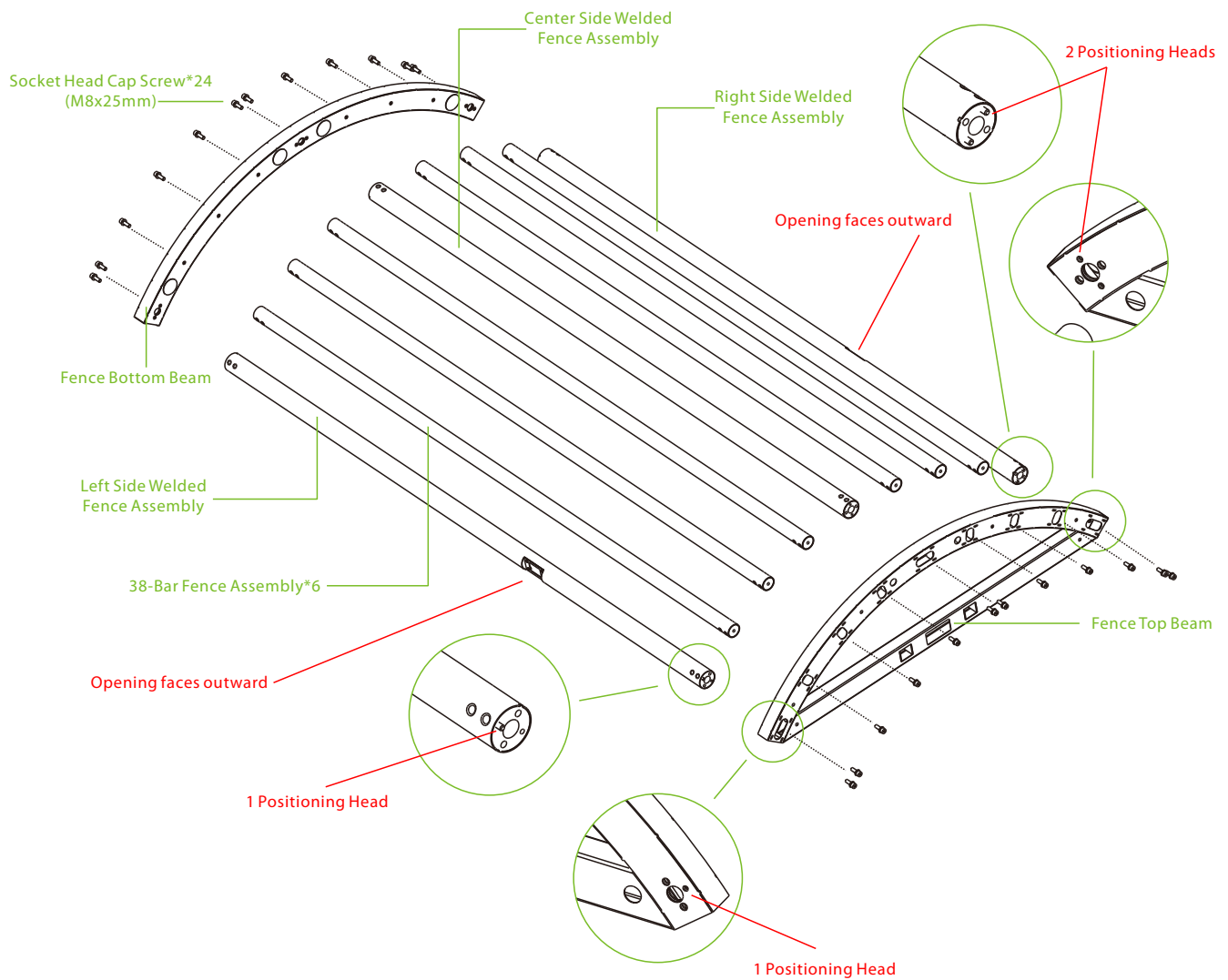

Step2: Install the Authentication Boxes

Install the left and right authentication boxes. Pay attention to the left/right orientation.

Secure them using eight M5×12mm socket head cap screws and four M4×6mm pan head screws with washers.

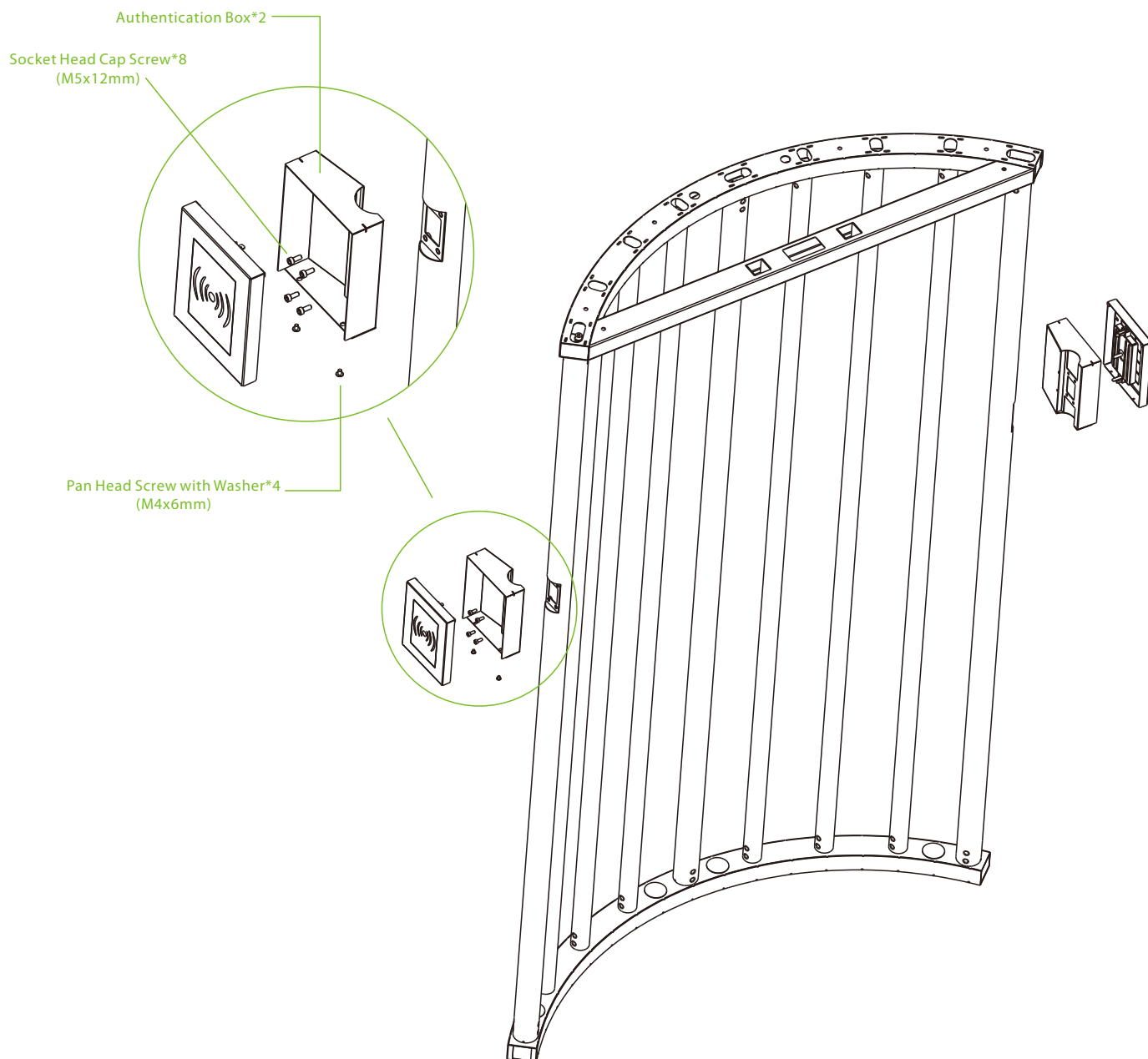

Step3: Assemble the Rotor Barrier

Assemble the three square shafts with 9-bar rotors using two shaft fixing blocks, and six each of lock nuts and hole plugs.

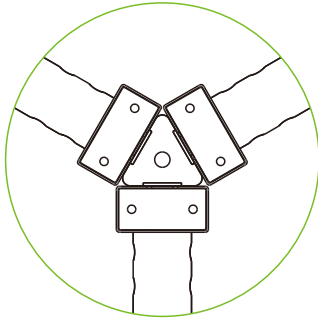

Top View

Square Shaft with 9-Bar Rotor Assembly

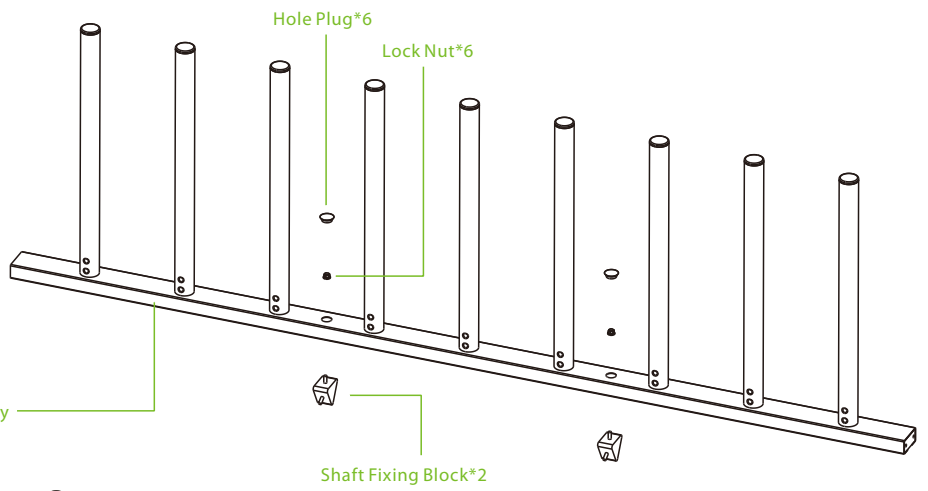

Shaft Fixing Block*2

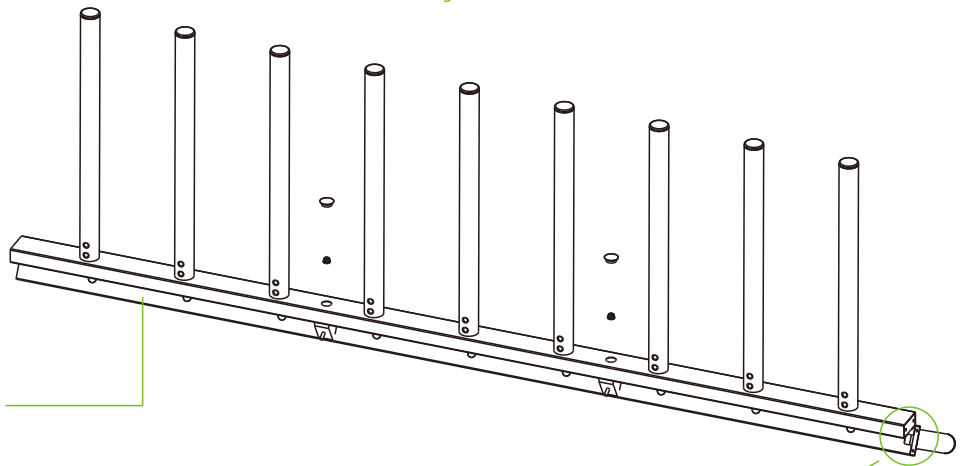

Square Shaft with 9-Bar Rotor Assembly*2

Align the notch

Square Shaft with 9-Bar Rotor Assembly*3

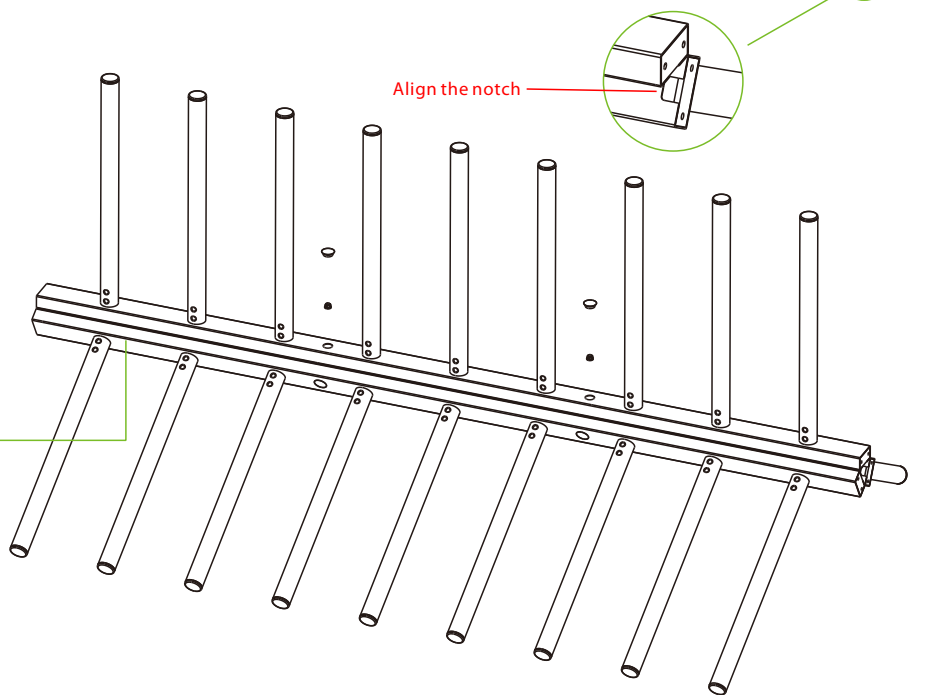

Step4: Install the Shaft End Cap

Install the shaft end cap on top of rotor barrier.

Secure using six M6x20mm socket head cap screws and six spring washers.

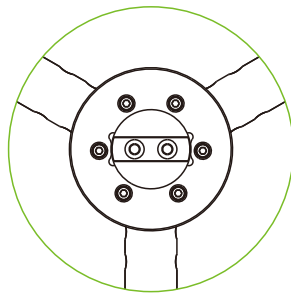

Top View

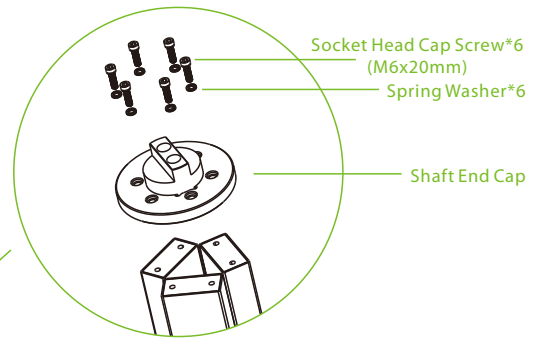

Socket Head Cap Screw*6
(M6x20mm)

Spring Washer*6

Shaft End Cap

Install the upper fixing mount flush and parallel with the rotor arms on the same side.

No notch

Parallel

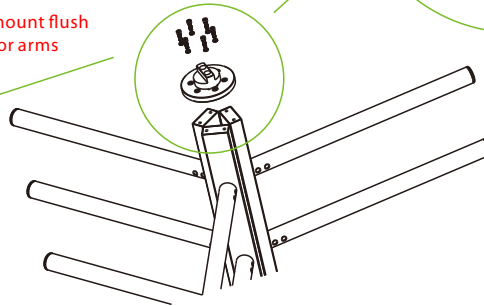
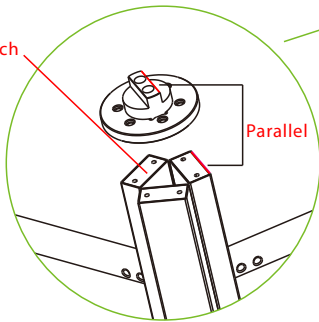

Step5: Install the Shaft Bottom Sleeve

Install the shaft bottom sleeve and shaft guard on bottom of rotor barrier.

Secure using six M6x20mm socket head cap screws and six spring washers.

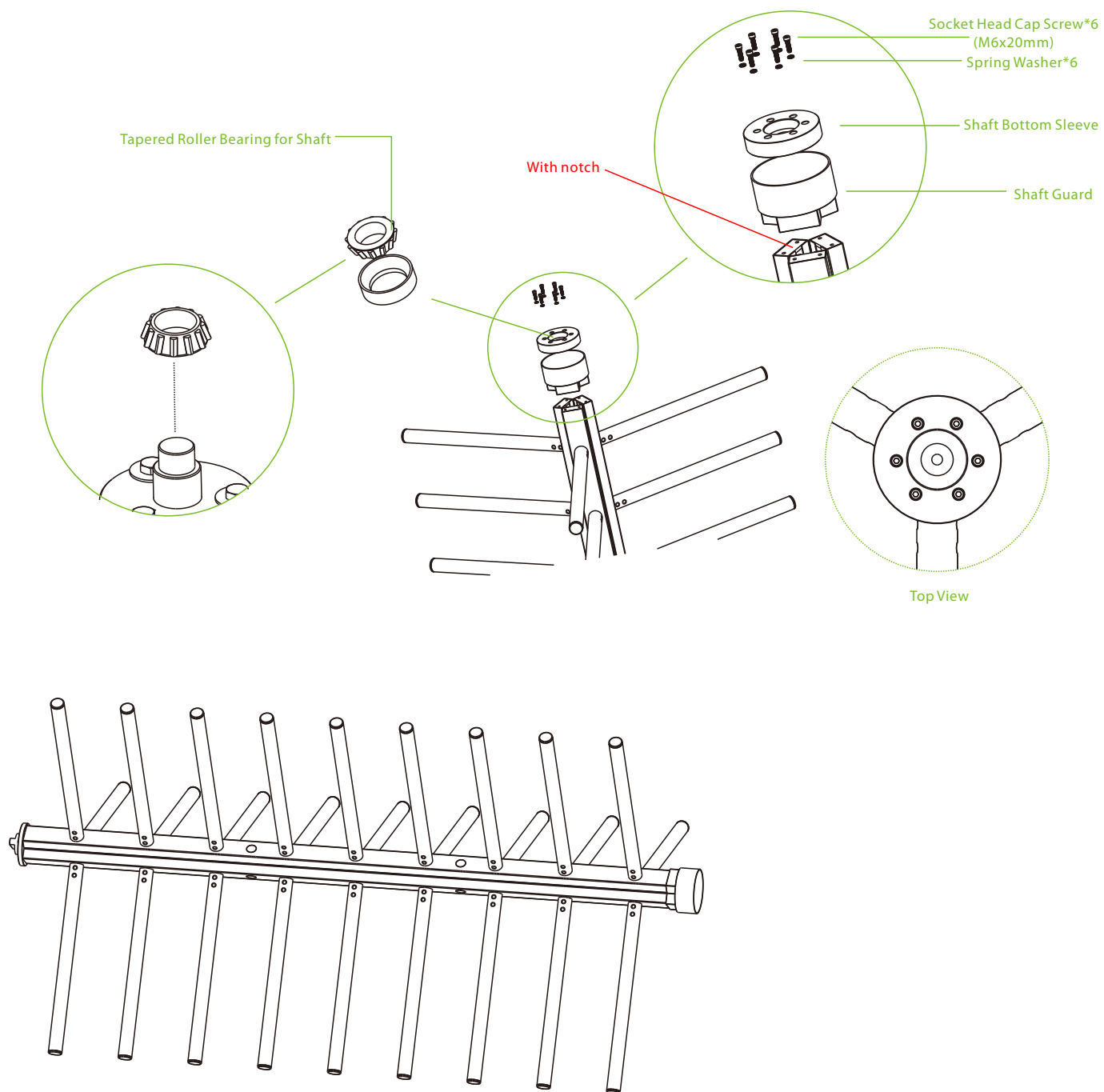

Step6: Fix the Fence Frames and Shaft Base

Drill eleven holes to a depth of 85mm according to the Expansion Bolt Positioning Jig.

Fix the fence frame, square tube right angle bracket and shaft base with eleven M12 internal expansion anchors.

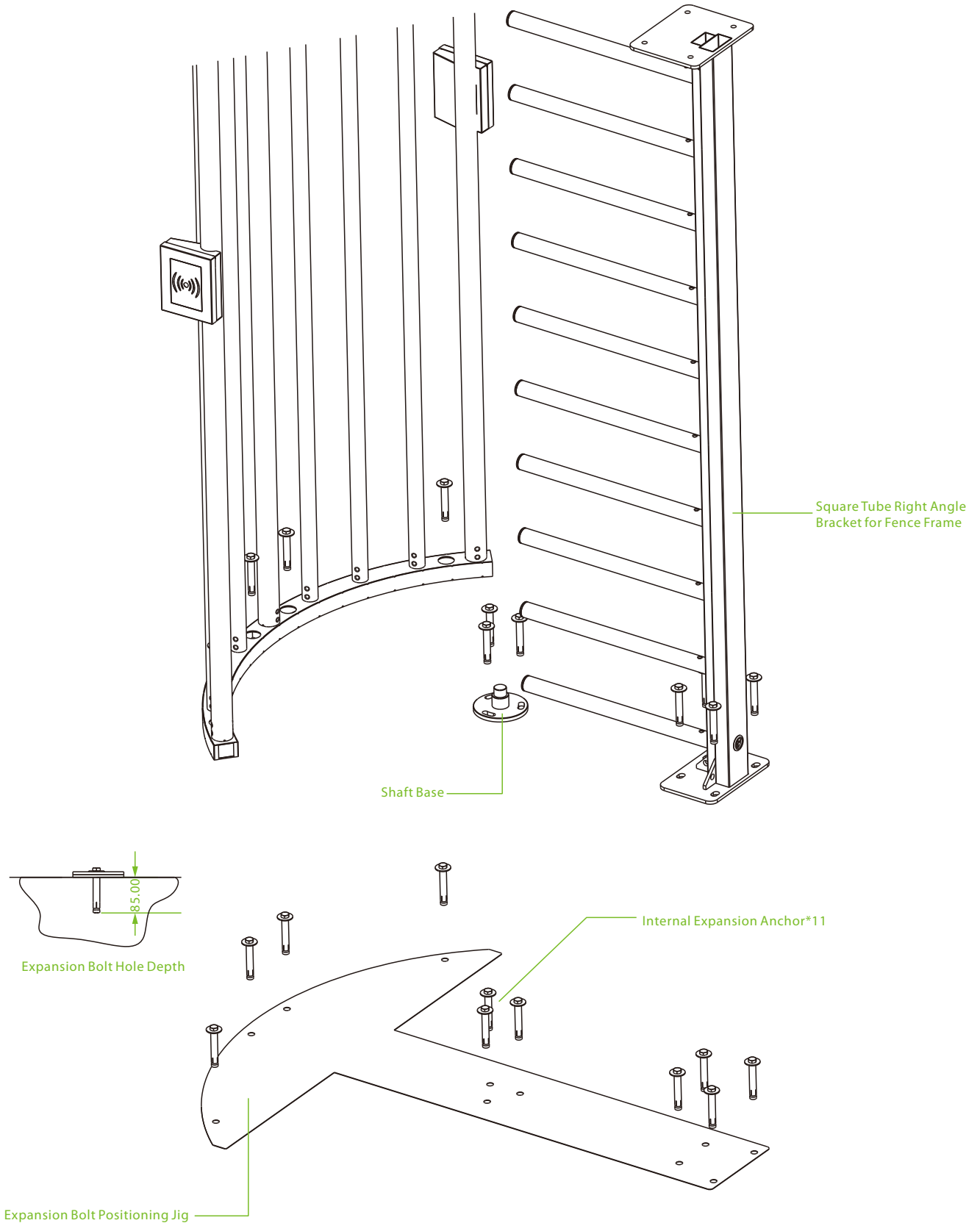

Step7: Install the Base Box and Ground Silicone Bumpers

Install the base box and four ground silicone bumpers.

Secure using three M3x6mm flat head Phillips screws.

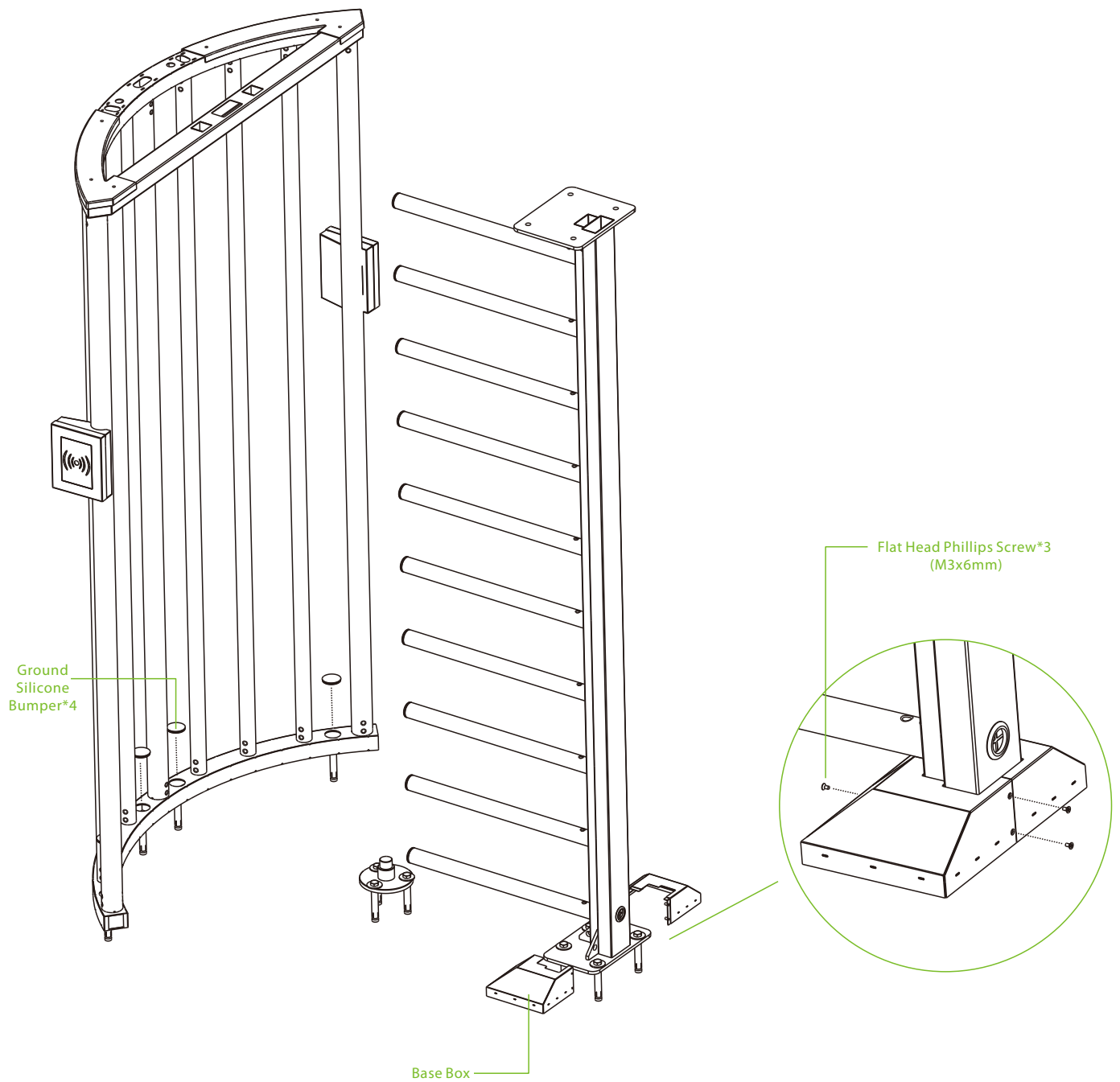

Step8: Install the Mechanism Housing

Mount the mechanism housing on top of the fence frames.

Secure it using four M10×60mm socket head cap screws and four M10×30mm socket head cap screws.

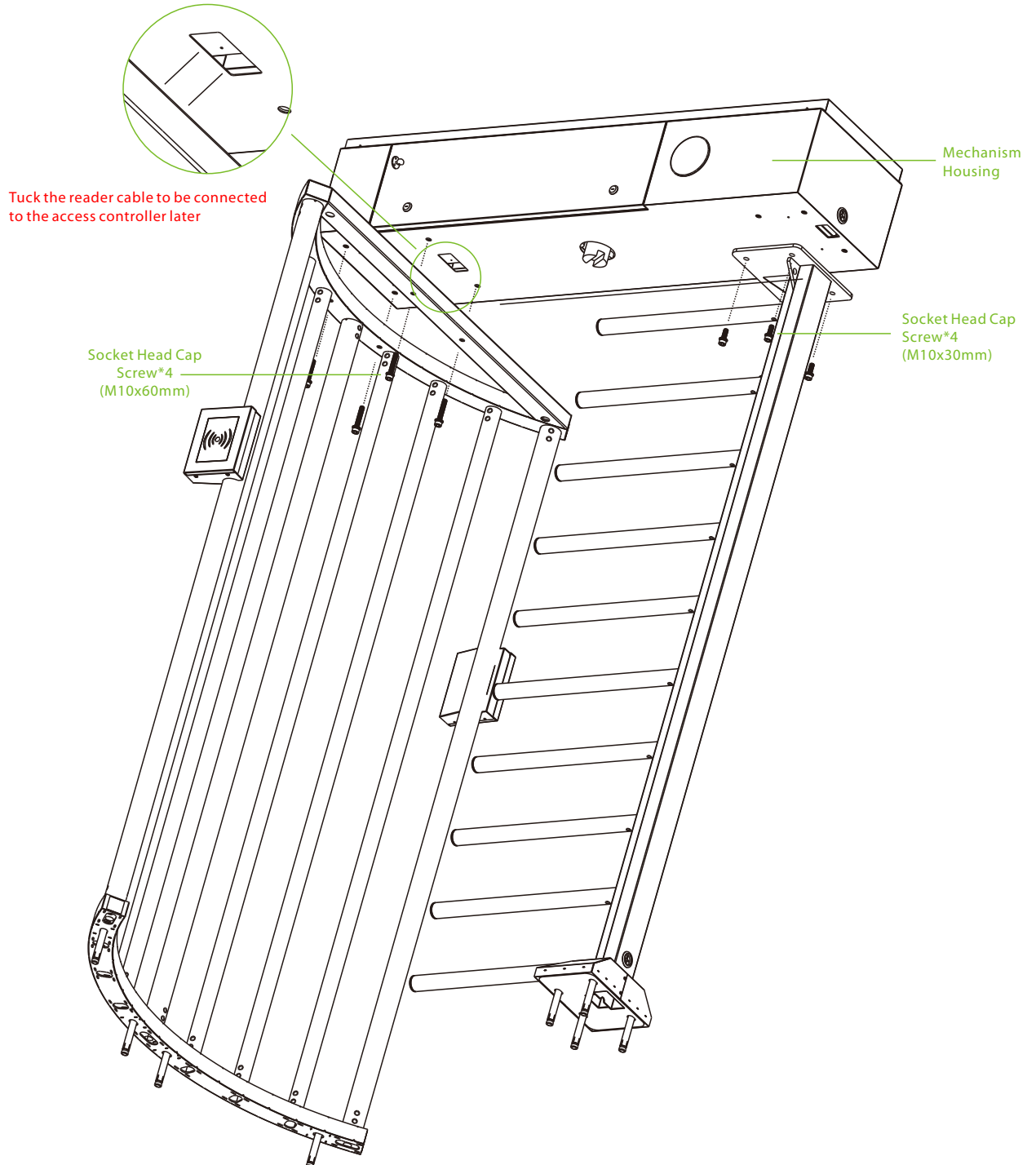

Step9: Install the Rotor Barrier

Place the tapered roller bearing on the shaft base, then install the rotor barrier on the shaft base.

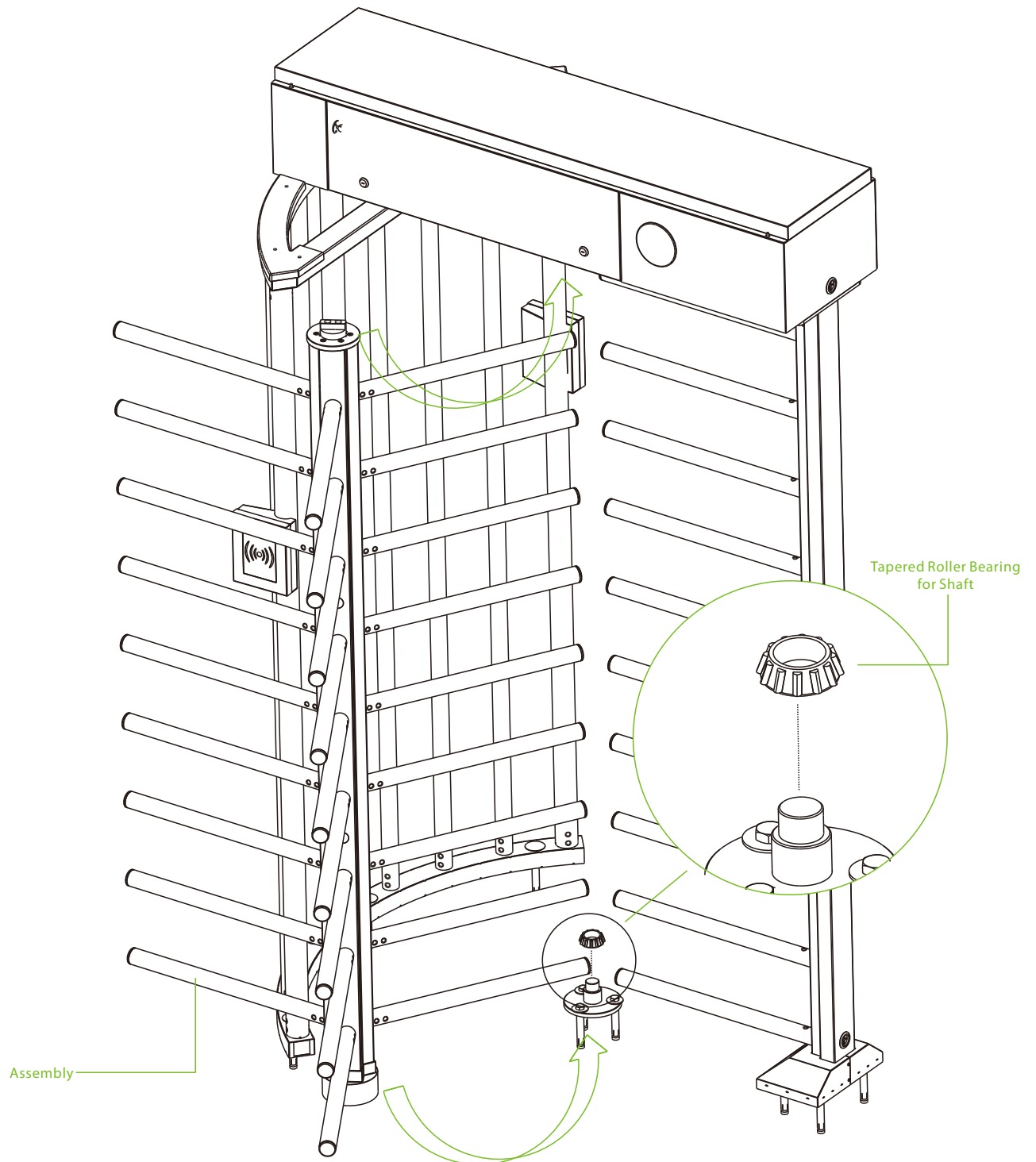

Before inserting the top of the rotor barrier into the mechanism housing, it is necessary to install the mechanism shaft sleeve on the bottom of the mechanism housing (The shaft sleeve need to be pushed up), and then insert the rotor barrier correctly under the mechanism housing.

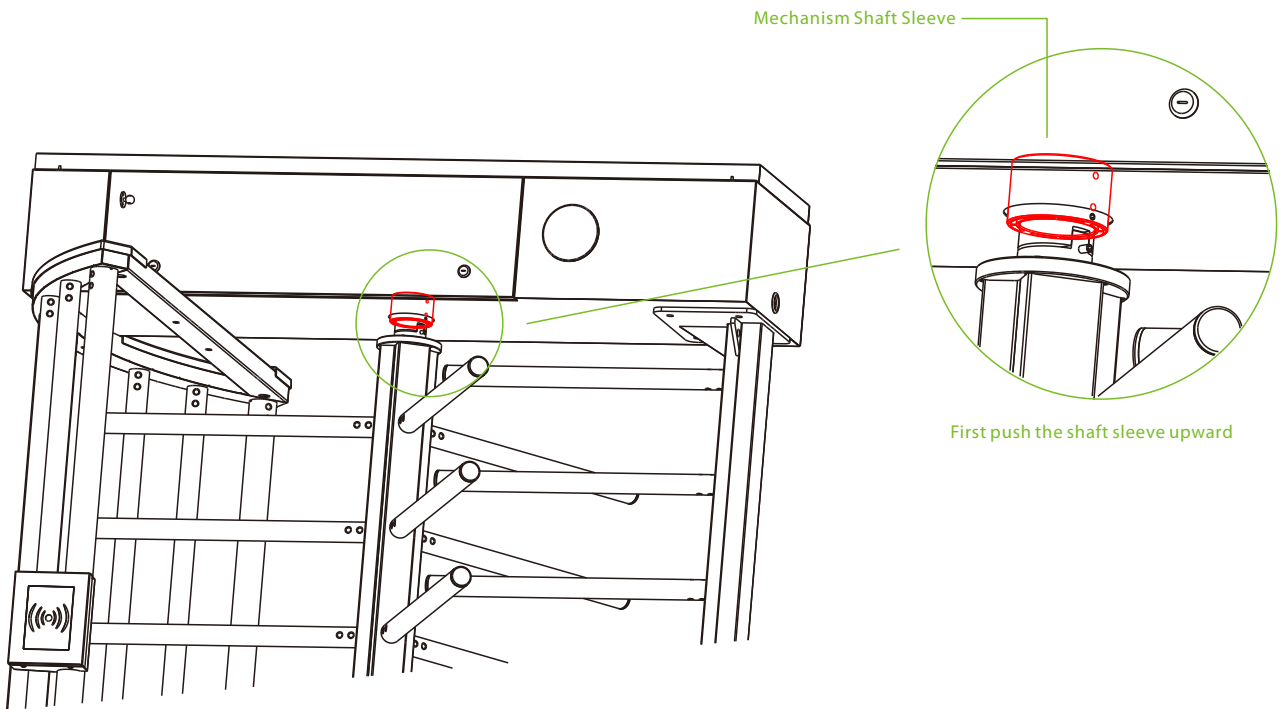

Use two M6x10mm hex socket flat point set screws to secure the rotor barrier.

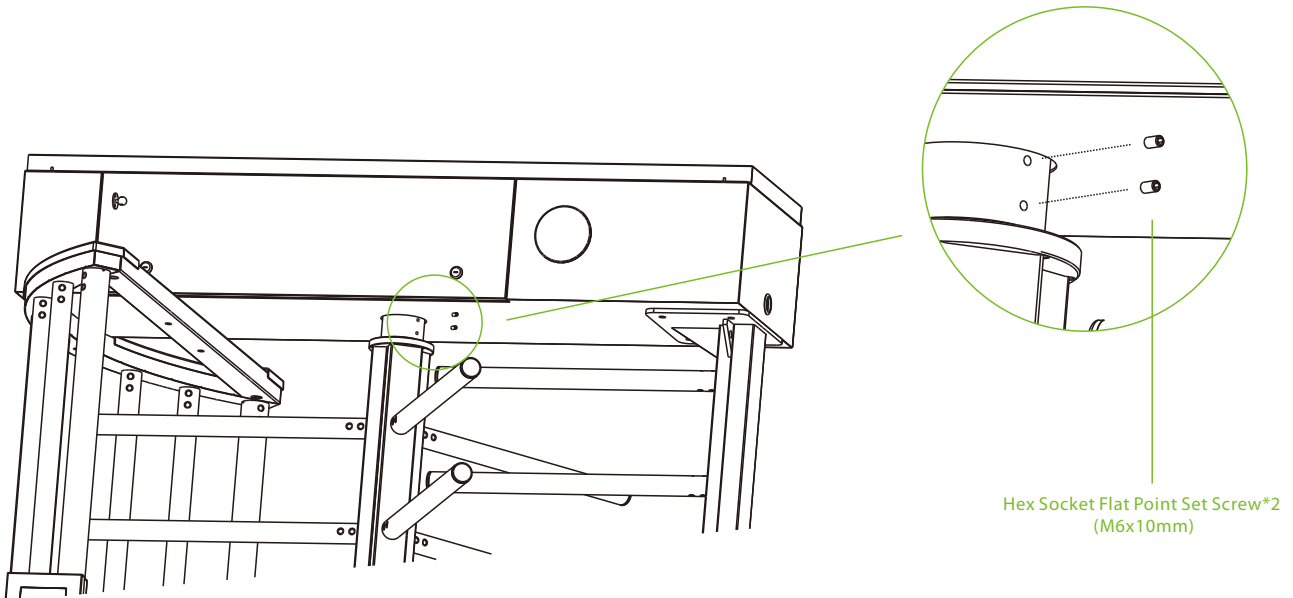

Step10: Install the Fence Guards

Install the left and right fence guards on the top of fence frame with six M6x16mm socket head cap screws.

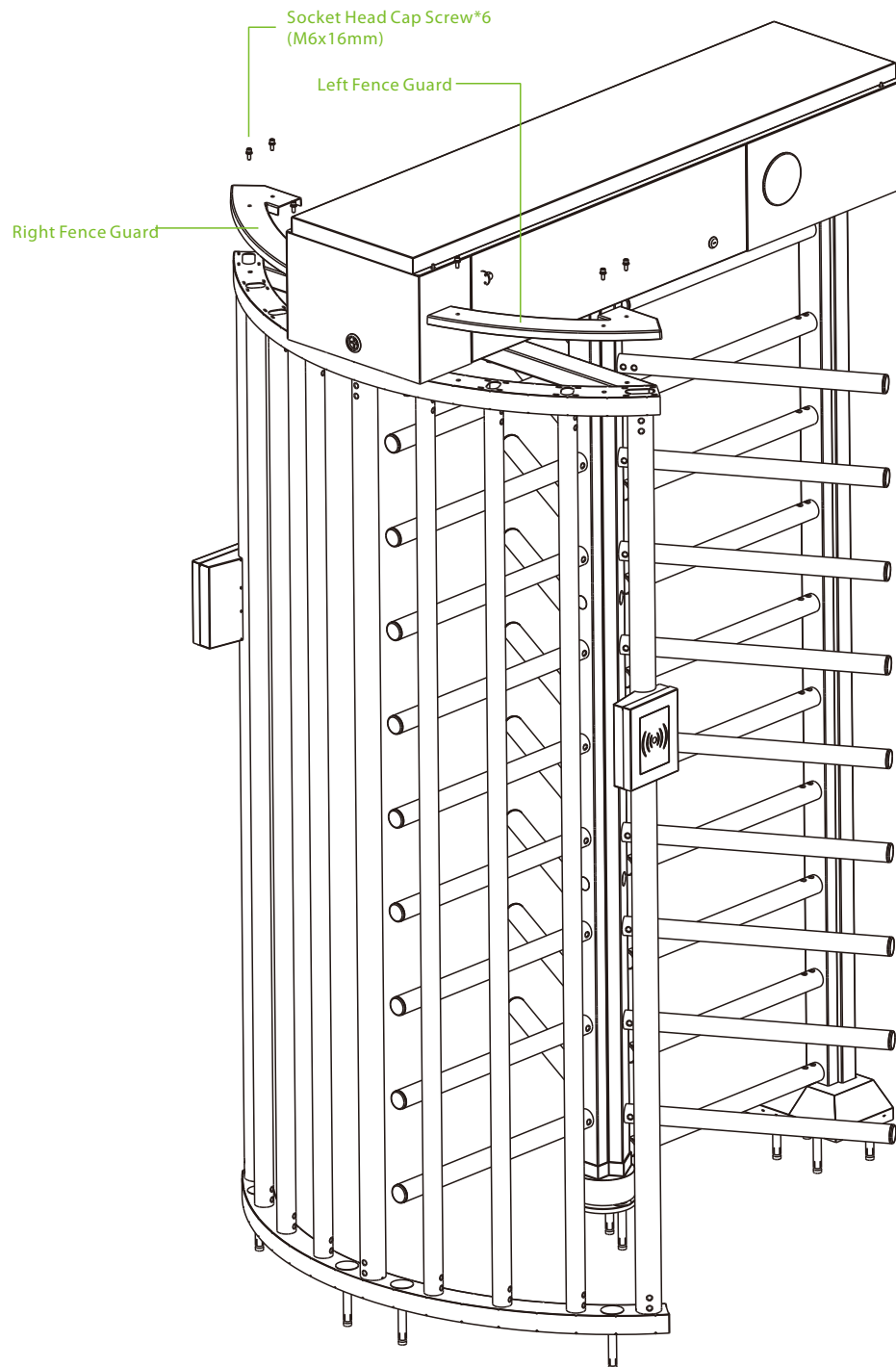

The installation is complete.

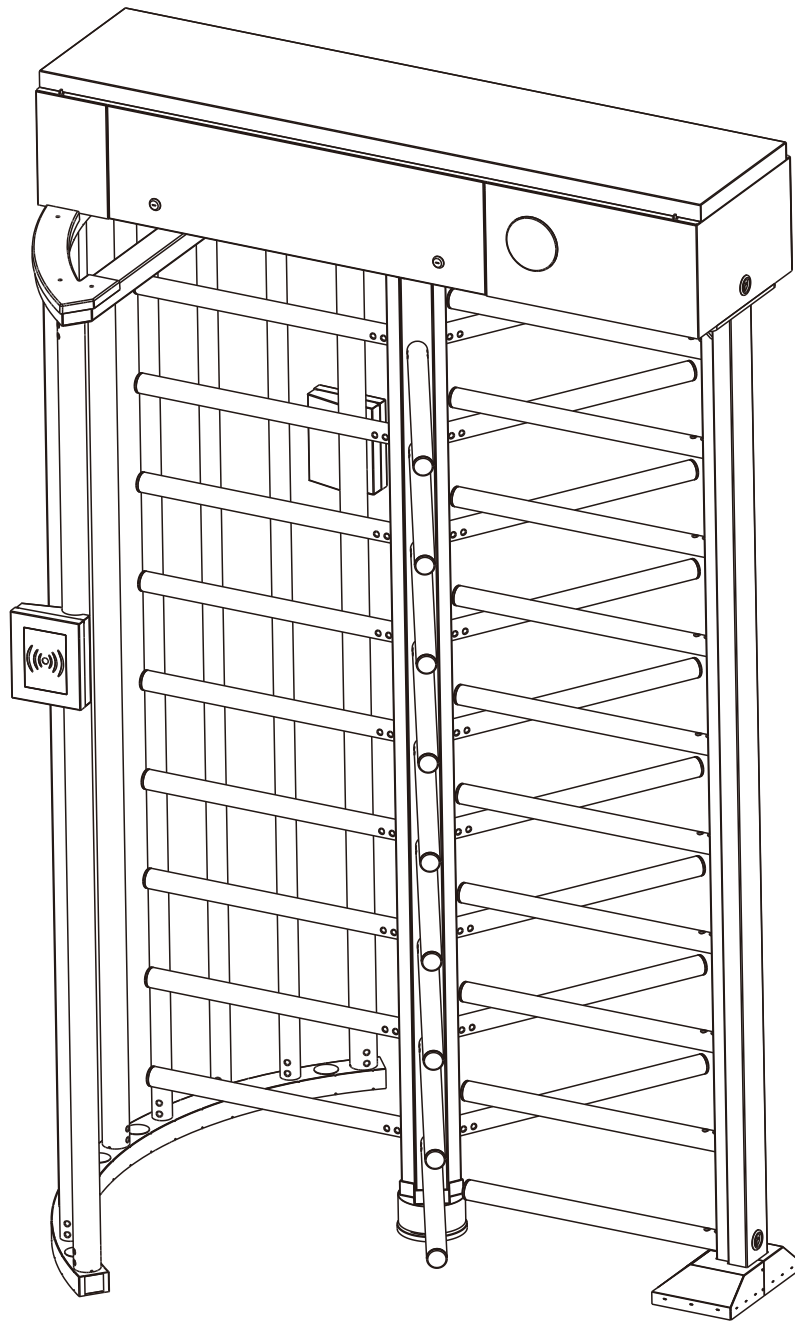

3 Wiring Diagram

After installation of the device, open the mainframe-box to connect power wire and reader. Remove the reader and power cord from both sides of the column and connect to the corresponding interface.

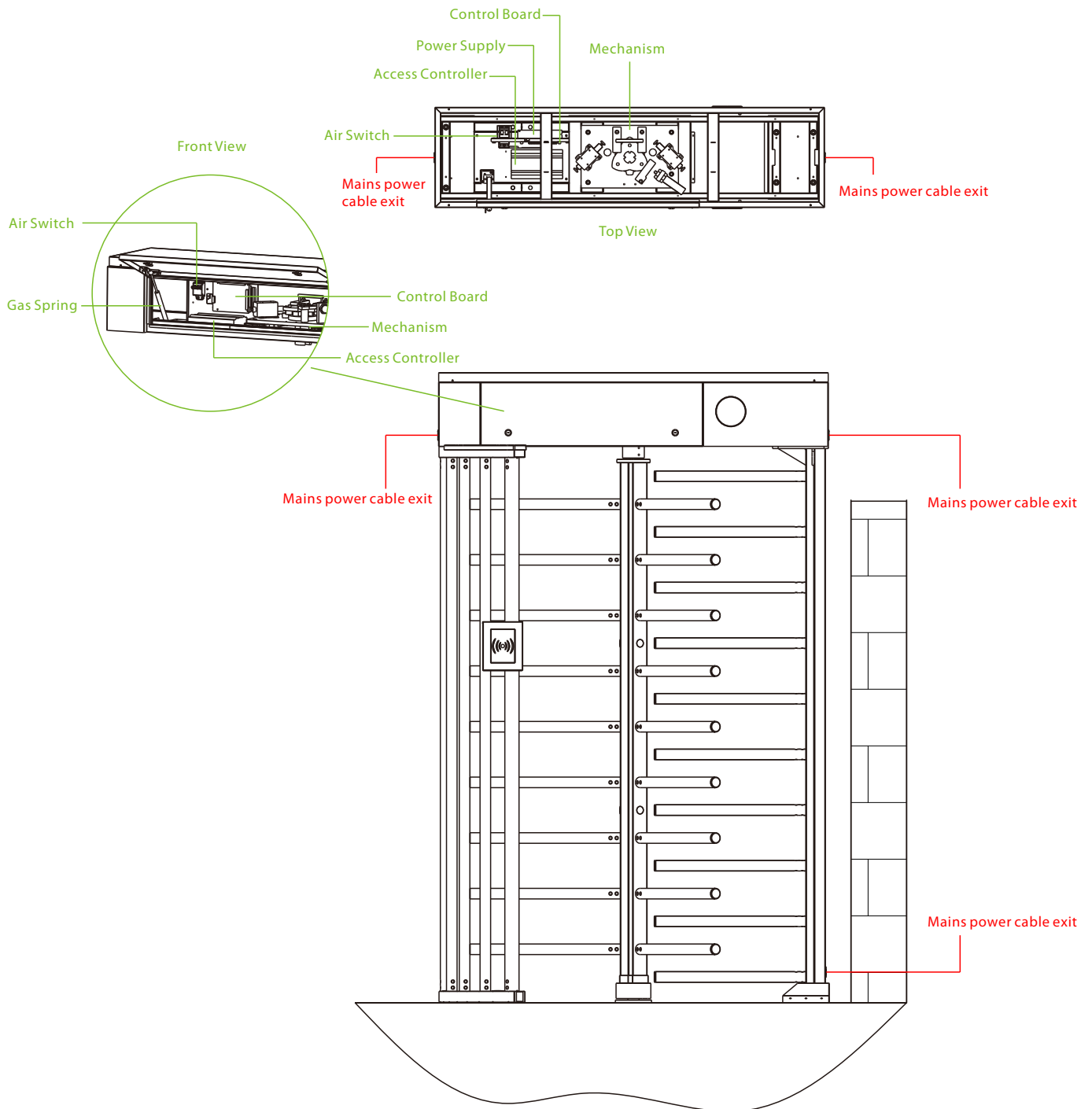

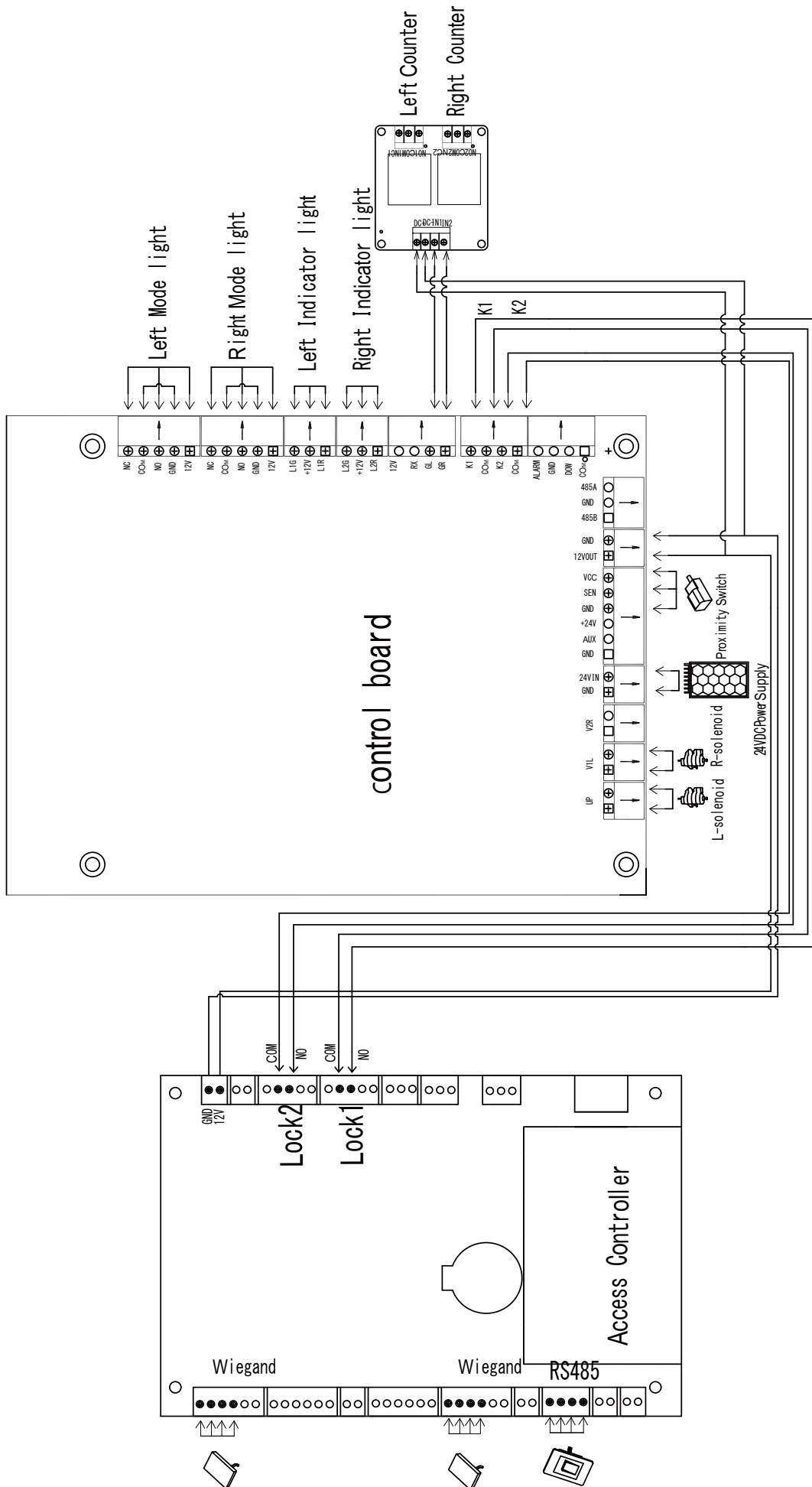

ZKTeco Industrial Park, No. 32, Industrial Road,

Tangxia Town, Dongguan, China.

Phone : +86 769 - 82109991

Fax : +86 755 - 89602394

www.zkteco.com

