

User Manual

Saturn-H1300

Date: May 2026

Doc Version: 1.0

English

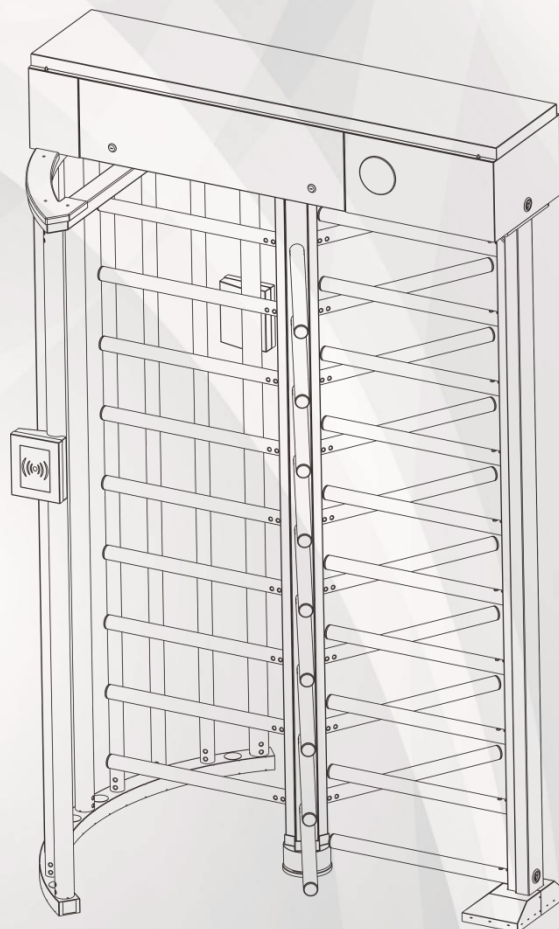

Copyright © 2026 ZKTECO CO., LTD. All rights reserved.

Without the prior written consent of ZKTeco, no portion of this manual can be copied or forwarded in any way or form. All parts of this manual belong to ZKTeco and its subsidiaries (hereinafter the "Company" or "ZKTeco").

Trademark

ZKTeco is a registered trademark of ZKTeco. Other trademarks involved in this manual are owned by their respective owners.

Disclaimer

This manual contains information on the operation and maintenance of the ZKTeco equipment. The copyright in all the documents, drawings, etc. in relation to the ZKTeco supplied equipment vests in and is the property of ZKTeco. The contents hereof should not be used or shared by the receiver with any third party without express written permission of ZKTeco.

The contents of this manual must be read as a whole before starting the operation and maintenance of the supplied equipment. If any of the content(s) of the manual seems unclear or incomplete, please contact ZKTeco before starting the operation and maintenance of the said equipment.

It is an essential pre-requisite for the satisfactory operation and maintenance that the operating and maintenance personnel are fully familiar with the design and that the said personnel have received thorough training in operating and maintaining the machine/unit/equipment. It is further essential for the safe operation of the machine/unit/equipment that personnel has read, understood and followed the safety instructions contained in the manual.

In case of any conflict between terms and conditions of this manual and the contract specifications, drawings, instruction sheets or any other contract-related documents, the contract conditions/documents shall prevail. The contract specific conditions/documents shall apply in priority.

ZKTeco offers no warranty, guarantee or representation regarding the completeness of any information contained in this manual or any of the amendments made thereto. ZKTeco does not extend the warranty of any kind, including, without limitation, any warranty of design, merchantability or fitness for a particular purpose.

ZKTeco does not assume responsibility for any errors or omissions in the information or documents which are referenced by or linked to this manual. The entire risk as to the results and performance obtained from using the information is assumed by the user.

ZKTeco in no event shall be liable to the user or any third party for any incidental, consequential, indirect, special, or exemplary damages, including, without limitation, loss of business, loss of profits, business interruption, loss of business information or any pecuniary loss, arising out of, in connection with, or

relating to the use of the information contained in or referenced by this manual, even if ZKTeco has been advised of the possibility of such damages.

This manual and the information contained therein may include technical, other inaccuracies or typographical errors. ZKTeco periodically changes the information herein which will be incorporated into new additions/amendments to the manual. ZKTeco reserves the right to add, delete, amend or modify the information contained in the manual from time to time in the form of circulars, letters, notes, etc. for better operation and safety of the machine/unit/equipment. The said additions or amendments are meant for improvement /better operations of the machine/unit/equipment and such amendments shall not give any right to claim any compensation or damages under any circumstances.

ZKTeco shall in no way be responsible (i) in case the machine/unit/equipment malfunctions due to any non-compliance of the instructions contained in this manual (ii) in case of operation of the machine/unit/equipment beyond the rate limits (iii) in case of operation of the machine and equipment in conditions different from the prescribed conditions of the manual.

The product will be updated from time to time without prior notice. The latest operation procedures and relevant documents are available on <http://www.zkteco.com>

If there is any issue related to the product, please contact us.

ZKTeco Headquarters

Address ZKTeco Industrial Park, No. 32, Industrial Road,
Tangxia Town, Dongguan, China.

Phone +86 769 - 82109991

Fax +86 755 - 89602394

For business-related queries, please write to us at: sales@zkteco.com.

To know more about our global branches, visit www.zkteco.com.

About the Company

ZKTeco is one of the world's largest manufacturer of RFID and Biometric (Fingerprint, Facial, Finger-vein) readers. Product offerings include Access Control readers and panels, Near & Far-range Facial Recognition Cameras, Elevator/floor access controllers, Turnstiles, License Plate Recognition (LPR) gate controllers and Consumer products including battery-operated fingerprint and face-reader Door Locks. Our security solutions are multi-lingual and localized in over 18 different languages. At the ZKTeco state-of-the-art 700,000 square foot ISO9001-certified manufacturing facility, we control manufacturing, product design, component assembly, and logistics/shipping, all under one roof.

The founders of ZKTeco have been determined for independent research and development of biometric verification procedures and the productization of biometric verification SDK, which was initially widely applied in PC security and identity authentication fields. With the continuous enhancement of the development and plenty of market applications, the team has gradually constructed an identity authentication ecosystem and smart security ecosystem, which are based on biometric verification techniques. With years of experience in the industrialization of biometric verifications, ZKTeco was officially established in 2007 and now has been one of the globally leading enterprises in the biometric verification industry owning various patents and being selected as the National High-tech Enterprise for 6 consecutive years. Its products are protected by intellectual property rights.

About the Manual

This manual introduces the operations of **Saturn-H1300**.

All figures displayed are for illustration purposes only. Figures in this manual may not be exactly consistent with the actual products.

Features and parameters with ★ are not available in all devices.

Safety Instruction



These instructions are intended to ensure that user can use the product correctly to avoid danger or property loss.

The precaution measure is divided into Dangers and Cautions:

Dangers: Neglecting any of the warnings may cause serious injury or death.

Cautions: Neglecting any of the cautions may cause injury or equipment damage.

Symbols

Convention	Description
	Dangers: Follow these safeguards to prevent serious injury or death.
	Cautions: Follow these precautions to prevent potential injury or material damage.



Dangers:

- In the use of the product, you must be in strict compliance with the electrical safety regulations of the nation and region.
- The equipment must be connected to an earthed mains socket-outlet.
- Shock hazard! Disconnect all power sources before maintenance.
- Do not touch the bare metal contacts of the inlets after the circuit breaker is turned off. Electricity still exists.
- To prevent possible hearing damage, do not listen at high volume levels for long periods.
- All the electronic operation should be strictly compliance with the electrical safety regulations, fire prevention regulations and other related regulations in your local region.
- Please use the power adapter, which is provided by normal company. The power consumption cannot be less than the required value.
- Do not connect several devices to one power adapter as adapter overload may cause over-heat or fire hazard.
- Please make sure that the power has been disconnected before you wire, install or dismantle the device.
- If the top caps should be open and the device should be powered on for maintenance, make sure:
 1. Power off the fan to prevent the operator from getting injured accidentally.
 2. Do not touch bare high-voltage components.
 3. Make sure the switch's wiring sequence is correct after maintenance.
- Please make sure that the power has been disconnected before you wire, install or dismantle the

device.

- If smoke, odors or noise rise from the device, turn off the power at once and unplug the power cable, and then please contact the service center.
- If the product does not work properly, please contact your dealer or the nearest service center. Never attempt to disassemble the device yourself. (We shall not assume any responsibility for problems caused by unauthorized repair or maintenance.)
- The Terminal PE of the switch should be connected to a ground wire.

Cautions:

- Instructions must be read before installation. Please follow these instructions carefully, incorrect installation could affect gate operation.
- When mounting and positioning this product please ensure the power cable is unplugged.
- The motor cover will need to be removed to mount the motor to the mounting plate. Electrical-related operation of the main unit can only be made by a licensed electrician.
- To prevent injury, this equipment must be securely attached to the floor/base of the turnstile in accordance with the installation instructions.
- Keep straight down when moving or using the equipment.
- Never place the equipment in an unstable location. The equipment may fall, causing serious personal injury or death.
- Stainless steel may be corroded in some circumstances. You need to clean and care the device by using the stainless steel cleaner. It is suggested to clean the device every month.
- Do not drop the device or subject it to physical shock, and do not expose it to high electromagnetism radiation. Avoid the equipment installation on vibrations surface or places subject to shock (ignorance can cause equipment damage).
- Do not place the device in extremely hot (refer to the specification of the device for the detailed operating temperature), cold, dusty or damp locations, and do not expose it to high electromagnetic radiation.
- The device cover for indoor use shall be kept from rain and moisture.
- Exposing the equipment to direct sun light, low ventilation or heat source such as heater or radiator is forbidden (ignorance can cause fire danger).
- Do not aim the device at the sun or extra bright places. A blooming or smear may occur otherwise (which is not a malfunction however), and affecting the endurance of sensor at the same time.
- Please use the provided glove when open up the device cover, avoid direct contact with the device cover, because the acidic sweat of the fingers may erode the surface coating of the device cover.
- Please use a soft and dry cloth when clean inside and outside surfaces of the device cover, do not use alkaline detergents.
- Please keep all wrappers after unpack them for future use. In case of any failure occurred, you need to

return the device to the factory with the original wrapper. Transportation without the original wrapper may result in damage on the device and lead to additional costs.

- Improper use or replacement of the battery may result in hazard of explosion. Replace with the same or equivalent type only. Dispose of used batteries according to the instructions provided by the battery manufacturer.
- Biometric recognition products are not 100% applicable to anti-spoofing environments. If you require a higher security level, use multiple authentication modes.
- Do not stay in the lane when the device is rebooting.
- RISK OF EXPLOSION IF BATTERY IS REPLACED BY AN INCORRECT TYPE. DISPOSE OF USED BATTERIES ACCORDING TO THE INSTRUCTIONS.
- SUITABLE FOR MOUNTING ON CONCRETE OR OTHER NON-COMBUSTIBLE SURFACE ONLY.
- The instructions shall require connection of the equipment protective earthing conductor to the installation protective earthing conductor.

Table of Contents

- 1 OVERVIEW..... 10**
 - 1.1 Features 10**
 - 1.2 Appearance and System Components 11**
 - 1.2.1 Appearance11
 - 1.2.2 System Components.....12
 - 1.3 Mechanical System 12**
 - 1.4 Electronic Control System 13**
 - 1.5 Power-On Self-Test 13**
 - 1.6 Working Principle..... 14**
 - 1.7 Technical Specifications..... 15**
- 2 FUNCTION INTRODUCTION 17**
 - 2.1 Card Verification★ 17**
 - 2.2 QR Code Verification★ 17**
 - 2.3 Fingerprint Verification★ 18**
 - 2.4 Facial Verification★ 19**
- 3 CONTROL SYSTEM INTRODUCTION 21**
 - 3.1 Wiring Diagram 21**
 - 3.2 Turnstile Control Board..... 22**
 - 3.3 Access Control Board★ 24**
 - 3.4 DIP K1 Switch Configuration..... 26**
- 4 MAINTENANCE 28**
 - 4.1 Chassis Maintenance 28**
 - 4.2 Movement Maintenance..... 28**
 - 4.3 Power Supply Maintenance 28**
- 5 PACKING LIST 29**

Revision History

Revision	Date	Author	Reviewer	Description
V1.0	05/21/2026	Stella Xia		Original Document.

1 Overview

The Saturn-H1300 Series integrates easily with fingerprint authentication, facial authentication, RFID card and QR code verification, fitting smoothly into your existing access control setup. Its bi-directional operation can be independently configured as controlled, locked, or free rotation, ensuring adaptable security for any environment. Saturn-H1300 Series is equipped with red and green LED indicators which provide clear visual guidance for users.

Also, the Saturn-H1300 is a high-security pedestrian access gate engineered for mobility - directly overcoming the key limitation of traditional full-height turnstiles, which are fixed and difficult to relocate. Designed for temporary access control, rapid deployment, and convenient transportation, it can be quickly disassembled into compact modules and redeployed across multiple sites, making it the practical choice wherever perimeter security needs change.

1.1 Features

Modular Design & Easy Mobility

- Disassembles into 3–5 modules for easier transport, handling, and storage.
- Net weight 152 kg (gross: 198 kg) — modular build enables relocation and redeployment by a small crew, no heavy equipment needed.
- Standard size (single lane): approx. 1400 × 1190 × 2265 mm.

High-Level Security Performance

- Full-height enclosure design that prevents climbing, vaulting, and crawling through.
- Mechanical anti-tailgating: only one person allowed per authorized pass.
- Anti-reverse entry (anti-passback), anti-collision.

Safety & Emergency Control

- Allow free passage during power failure (fire safety mode).
- Automatic locking when power is restored.
- Unlocks immediately upon receiving a fire signal for emergency evacuation.

Reliable Operation

- Silent and smooth operation.
- Service life 2 million cycles.

Access Control Compatibility

- Supports tech cards, QR codes, facial recognition, fingerprint.

1.2 Appearance and System Components

1.2.1 Appearance

The appearance and dimensions of Saturn-H1300 are shown in the figure below (unit: mm):

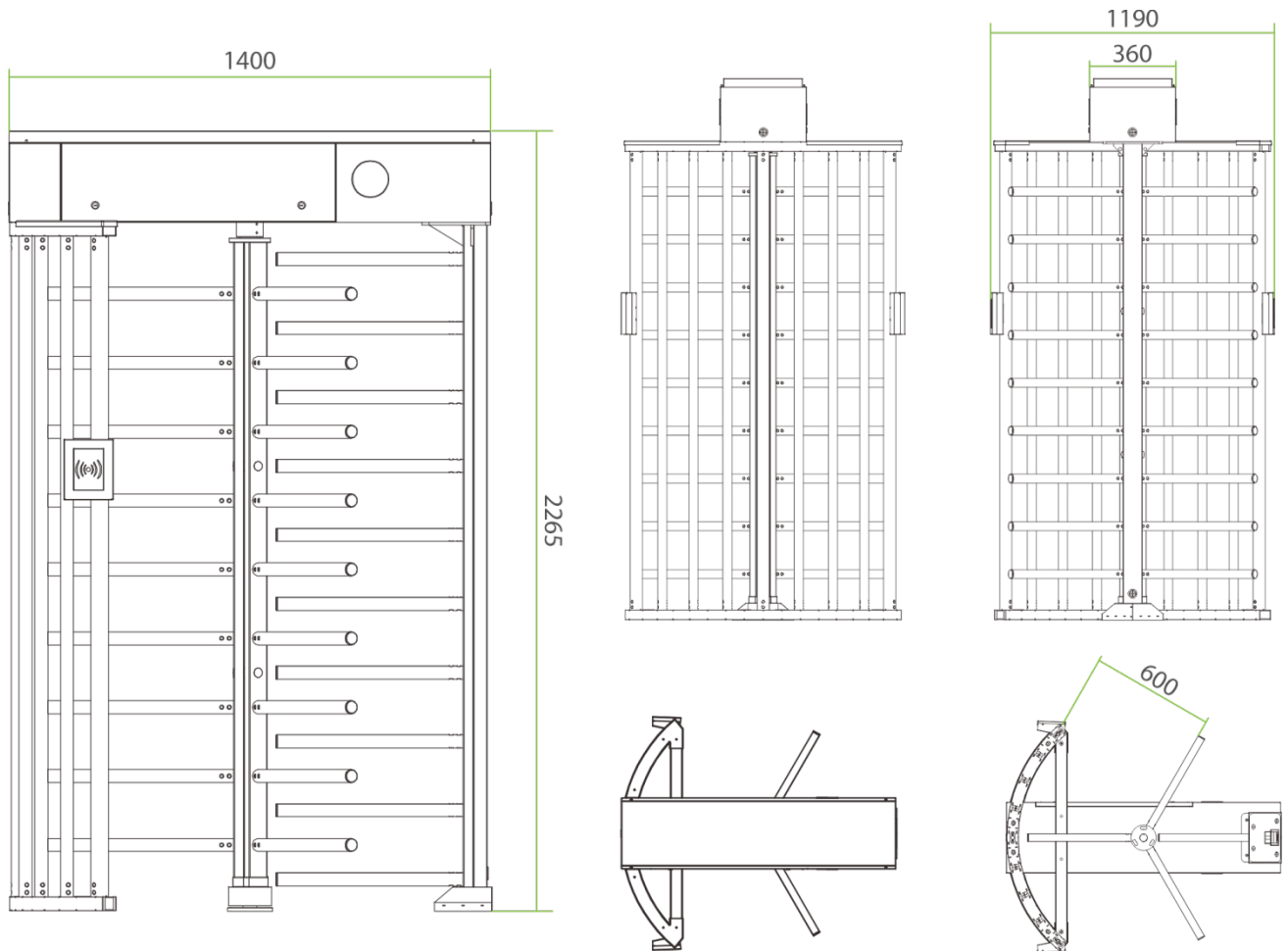

1.2.2 System Components

The system components of Saturn-H1300 are shown below:

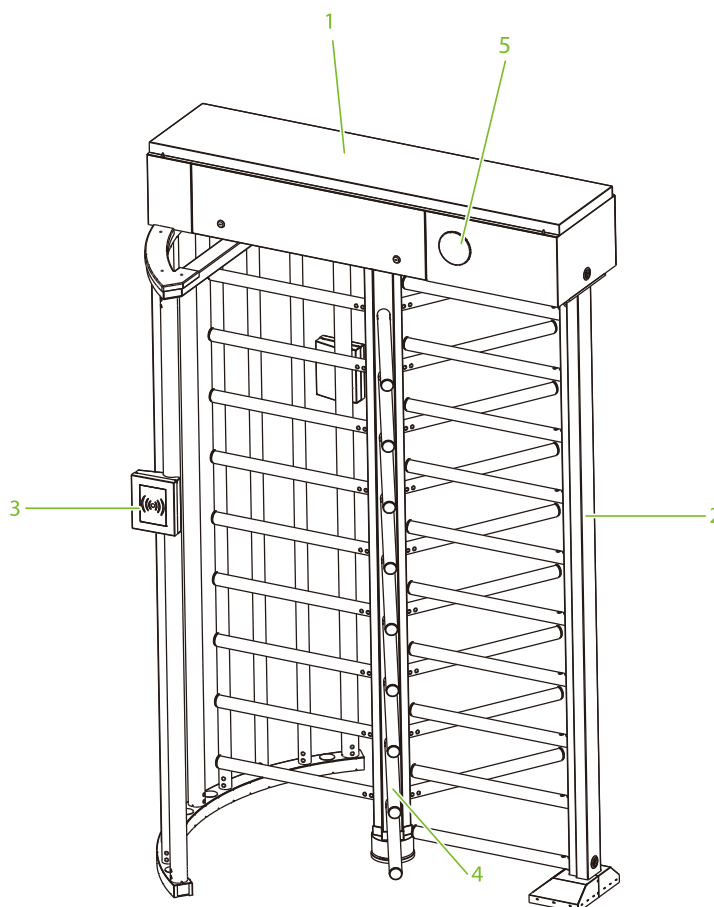

1. Mainframe Box	2. Stator Bar Frame
3. Verification Units	4. Rotor Barrier
5. Traffic Indicator	

1.3 Mechanical System

The mechanical system of the full height turnstile consists of a mainframe box and a frame.

The direction indicator, core, control panel, access controller and lock are installed in the mainframe box. The core component mainly consists of two solenoids, a spring and a transmission mechanism.

The frame supports the entire mainframe box.

1.4 Electronic Control System

The electronic control system of the full height turnstile is composed of the reader, control panel, access controller, direction indicator, alarm, and transformer.

Reader★: The reader reads the data in the card and sends it to the Access Controller.

Turnstile Control Board: The turnstile control board serves as the control center of the system. It receives signals from the reader and the dry contact, performs logical calculations and processing of these signals, and sends executive commands to the barrier.

Traffic Indicator: The system will illuminate the red indicator when the gate is closed. When someone passes the verification, the system will illuminate the green indicator.

Alarm: The alarm emits voice and light signals if the system detects any unauthorized entry to the passage, false direction entry, anti-tailgate or other violations.

1.5 Power-On Self-Test

1. Please make sure that the power requirements are strictly met to avoid permanent damage to the unit. Input voltage: AC 100 to 120V /200 to 240V. Note: The full height turnstile must be connected to the ground (earth).
2. Power on the full height turnstile and wait for 30 seconds for it to complete the self-test program.
3. Manually rotate the rotor arms clockwise,, as shown in the diagram below:

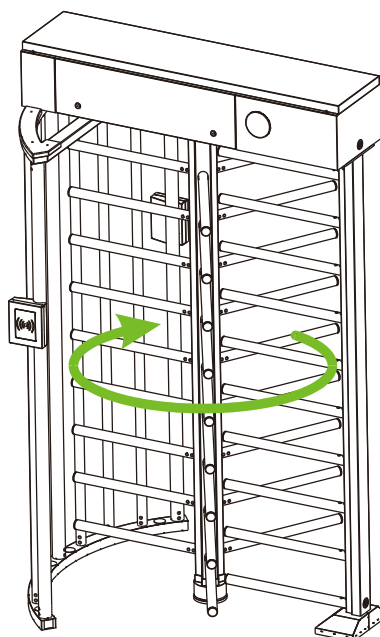

4. Check whether the full height turnstile and the LED indicator work properly. If there is any problem, please contact the supplier for assistance.

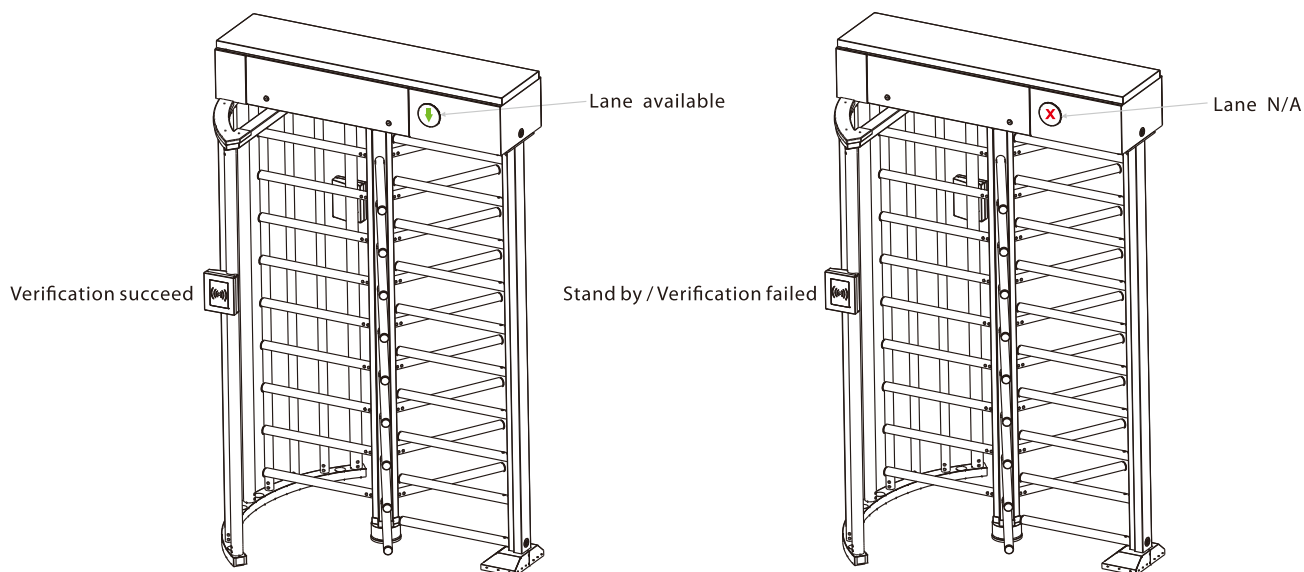

1.6 Working Principle

1. When connecting the device to the power source, the system initiates a Power-On Self-Test. If no issues are detected, the device will operate normally.
2. When a valid card is presented, the traffic indicator will send a green indicator to the pedestrian to indicate that the verification is successful. Subsequently, the card reader sends signals to the Access Controller, requesting permission to pass through the passage. The Access Controller, in turn, sends the signal to the Turnstile Control Board.
3. After receiving the signal from the card, the Turnstile Control Board will transmit valid control signals to the unlock solenoid driver. If the system is in the forbidden passing mode, the mode indicator light will turn red, and the Turnstile Control Board will not accept any card signals.
4. Pedestrians should follow the traffic indicator and gently push the unlocked Rotor Barrier; the Rotor Barrier will rotate till the pedestrian passes through the lane.
5. The pedestrian can only pass through the lane after a valid card has been successfully verified.

Note: Make sure that the ground wire of the system is reliably connected to avoid personal injuries or other accidents.

1.7 Technical Specifications

Feature	Specification
Model Name	Saturn-H1300
Visual Indicator	LED visual indicators integrated into the vertical column Red cross: passage denied Green arrow: passage allowed
Lane Type	Single lane
Lane Width	600mm
Lane Height	2265
Footprint (L*W)	1400*1190
Rotor Movement Type	Full-height rotating turnstile
Rotor Diameter	38mm
Rotor Arm Configuration	3-blade rotor
Rotor Arms	9
Throughput Rate	Max. 20 to 25 people per minute
Rotor Arm Material	Stainless steel
Cabinet Material	SUS304 stainless steel (the housing features a precision 240# hairline finish) / (SUS316 stainless steel optional)
Lid Material	SUS304 stainless steel (the housing features a precision 240# hairline finish) / (SUS316 stainless steel optional)
Motherboard Function	System configuration, entry log memory, safety logic
Motherboard Communication	Fire alarm port (Relay)*1, RS485 port*1
Controller	Standard full height turnstile controller
Credential Options	RFID reader: ProID10 Fingerprint reader: FR1500S or 3rd-party readers QR Code reader: QR500 Compatible with ZKTeco and third-party facial recognition standalone access control terminals
Flow Rate	RFID: 20 passengers per minute Fingerprint: 15 passengers per minute QR Code: 20 passengers per minute Facial Authentication: 15 passengers per minute
Accessibility	600mm (23.62") standard lane for pedestrians
Power Supply	100-120VAC or 200-240VAC, 50/60Hz
Power Rating	40W
Noise Level	Less than 60 dB
MCBF	2 million
Weight	Net Weight: 152kg Gross Weight: 198kg
Dimension (L*W*H)	1400*1190*2265mm

Dimensions with Packing (L*W*H)	2150*760*703mm
Operating Temperature	-28°C to 60°C
Operating Humidity	0% to 95% RH (non-condensing)
Certifications	CE, FCC (pending)
Ingress Protection Rating	IPX4
Supported Software	ZKBio CVSecurity (depends on the access controller installed)
Safety Features	Emergency escape function
Security Features	Anti-passback, Anti-tailgating
Product Delivery	Pre-assembled for easy installation
Application Environment	Indoor and Covered Outdoor
Site Preparation	Flat and level finished floor (optional base plate for unfinished floors)
Security Level	High
Emergency Mode	Rotor unlocks automatically during emergencies
Packing Material	Wooden Box
Warranty	1 year

2 Function Introduction

2.1 Card Verification★

The Card Verification mode compares the card number in the card induction area with all of the card number data registered in the device and sends it to the Access Controller.

When a user presses his / her card on the card reading area, the device enters card authentication mode.

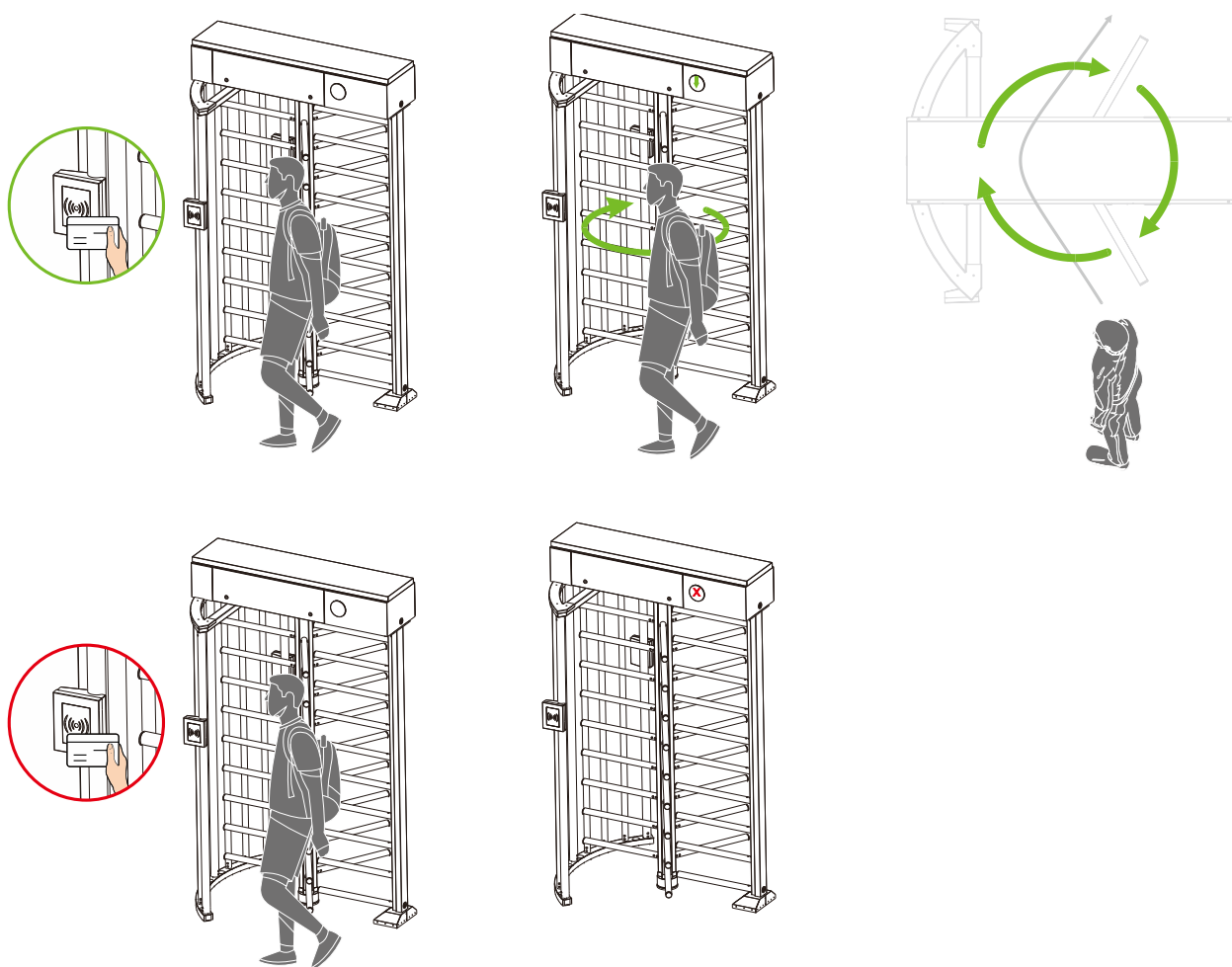

2.2 QR Code Verification★

The QR code Verification mode is to scan the QR code on the user's mobile phone through the QR code scanner and compare the data with the registered QR code, and then sends it to the Access Controller.

When the user places the mobile phone displaying with the QR code on top of the QR code scanner, the device enters the QR code authentication mode.

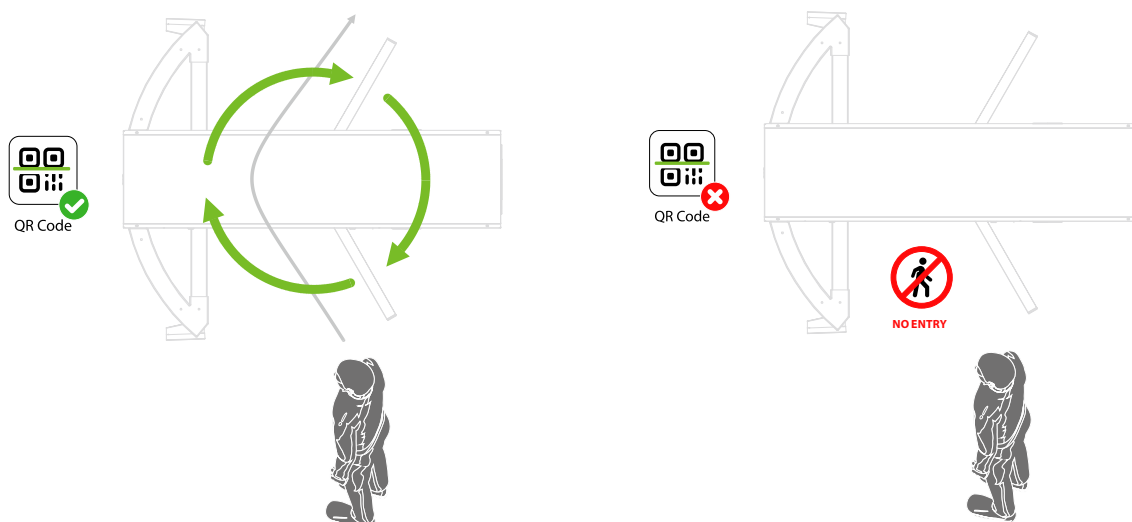

2.3 Fingerprint Verification★

In this verification mode, the device compares the fingerprint that is being pressed onto the fingerprint reader with all the fingerprint data sends it to the Access Controller.

The device enters the fingerprint authentication mode when a user presses his/her finger onto the fingerprint scanner.

Recommended fingers: It is recommended to use index, middle, or ring finger for registration and avoid using the thumb or little finger, as they are difficult to accurately press onto the fingerprint reader.

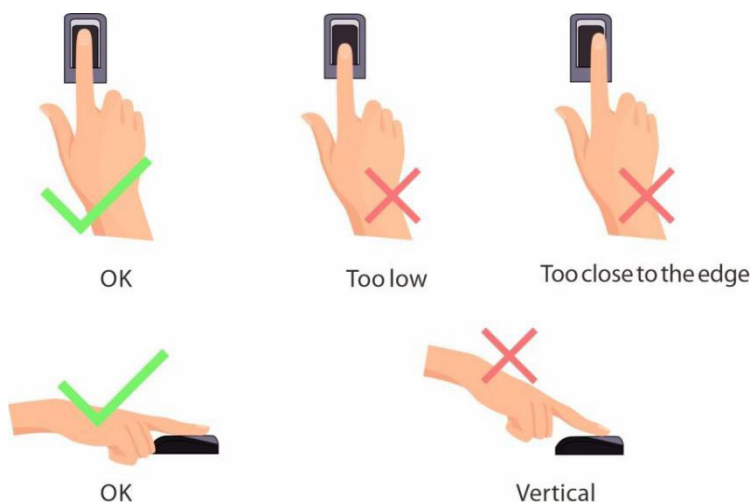

Note: Please use the correct method when pressing your fingers onto the fingerprint reader for registration and identification. Our company will assume no liability for recognition issues that may

result from incorrect usage of the product. We reserve the right of final interpretation and modification concerning this point.

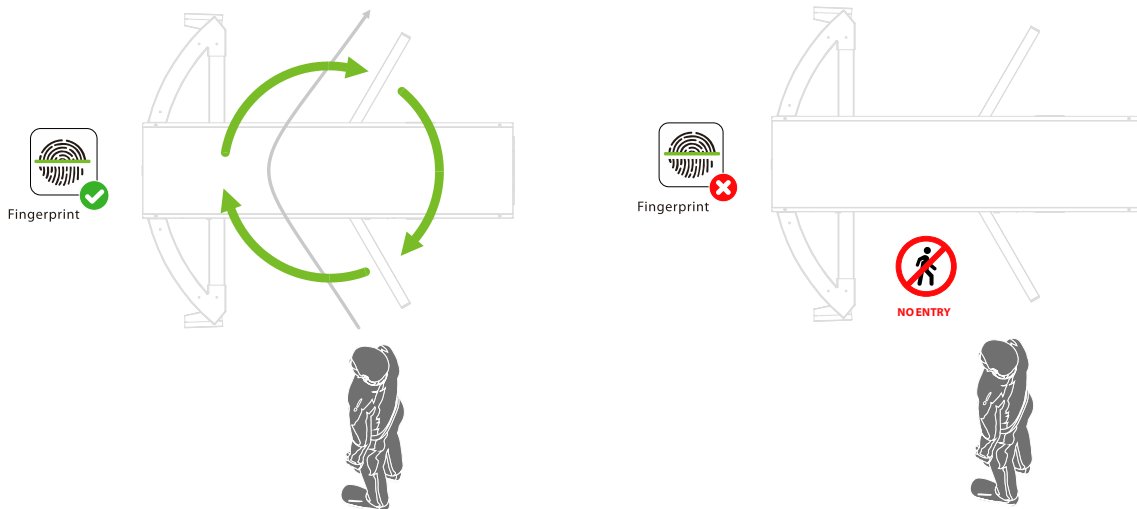

2.4 Facial Verification★

In this verification mode, the device compares the collected facial images with all face data registered in the device and then sends it to the Access Controller.

Try to keep the face in the centre of the screen during authentication. Please face towards the camera and stay still during face registration.

Recommended Standing Posture and Facial Expression:



Note: Please keep your facial expression and standing posture natural while enrollment or verification.

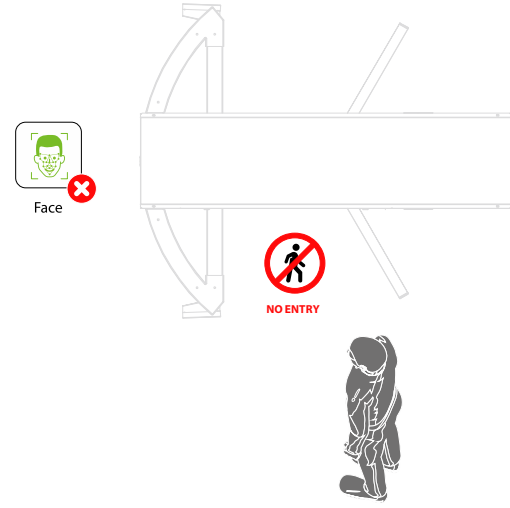
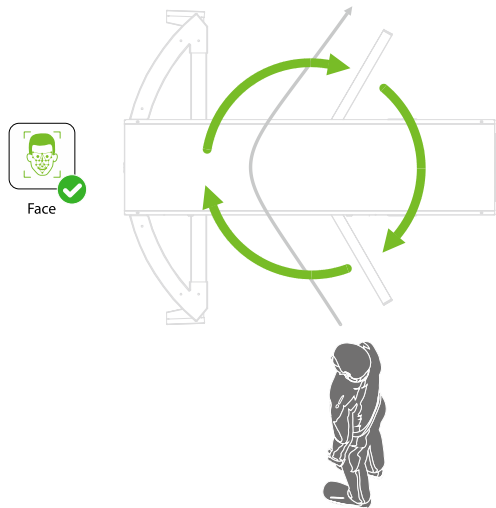





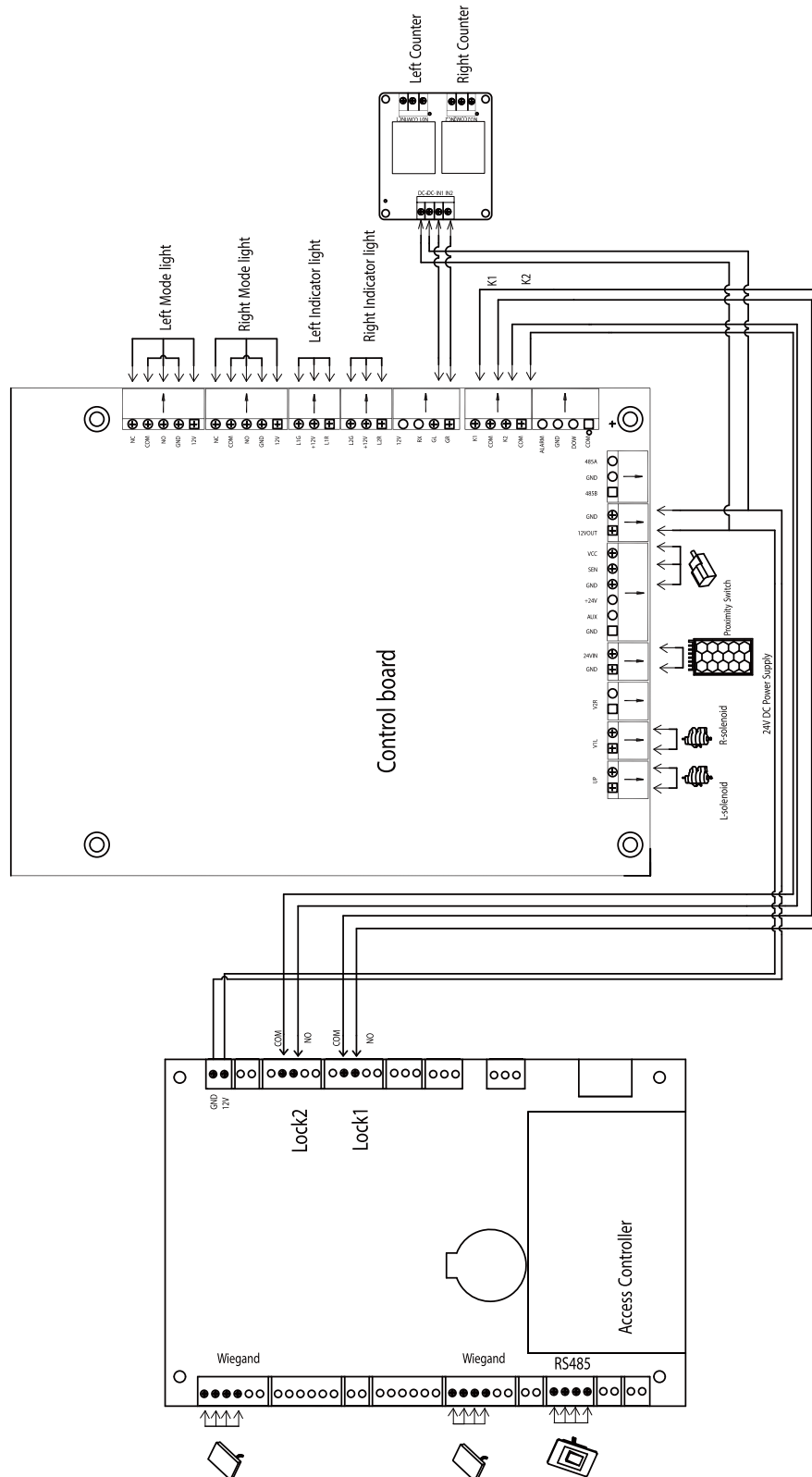



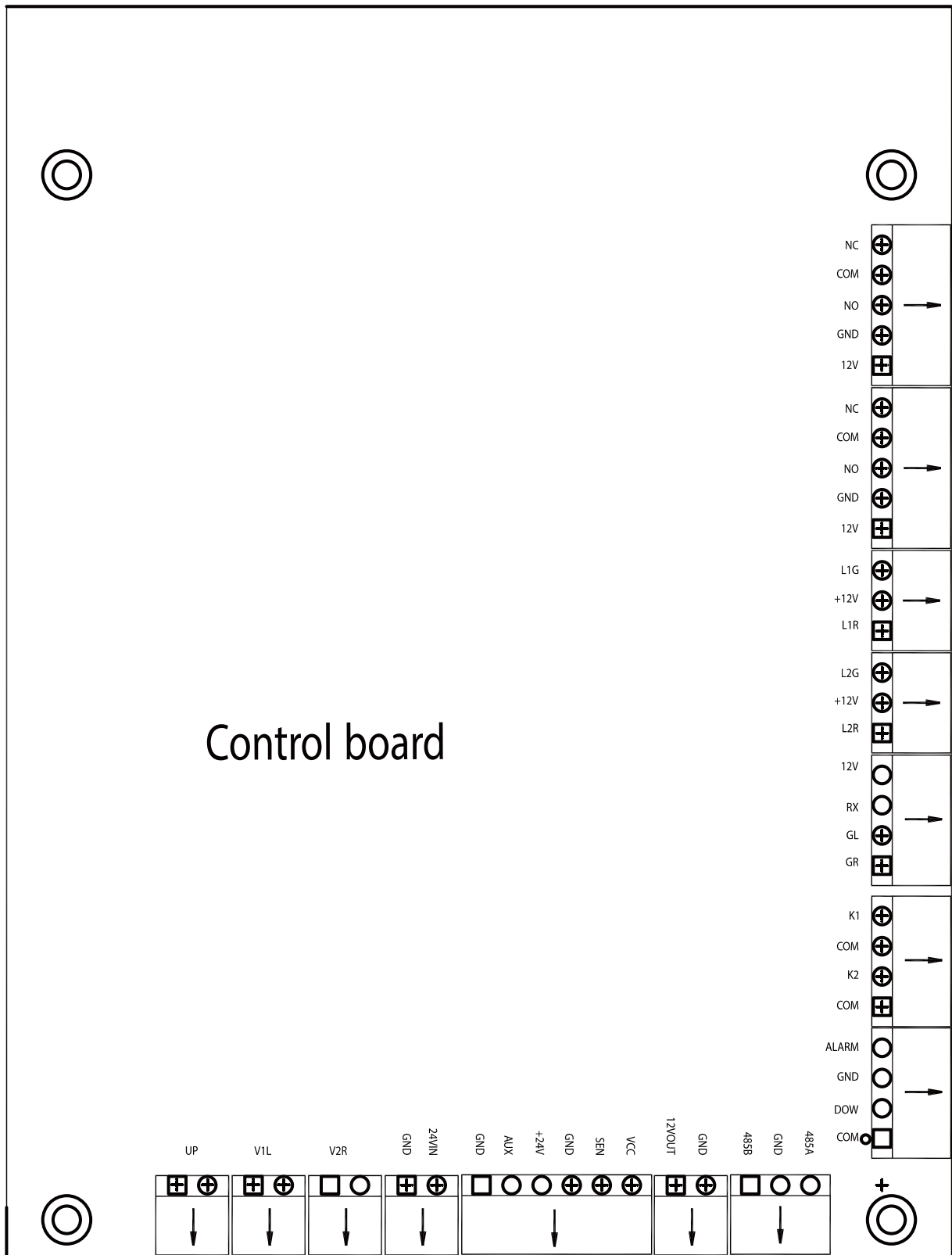

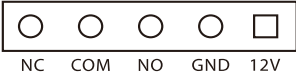
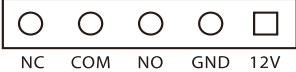

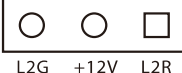
3 Control System Introduction

3.1 Wiring Diagram





3.2 Turnstile Control Board





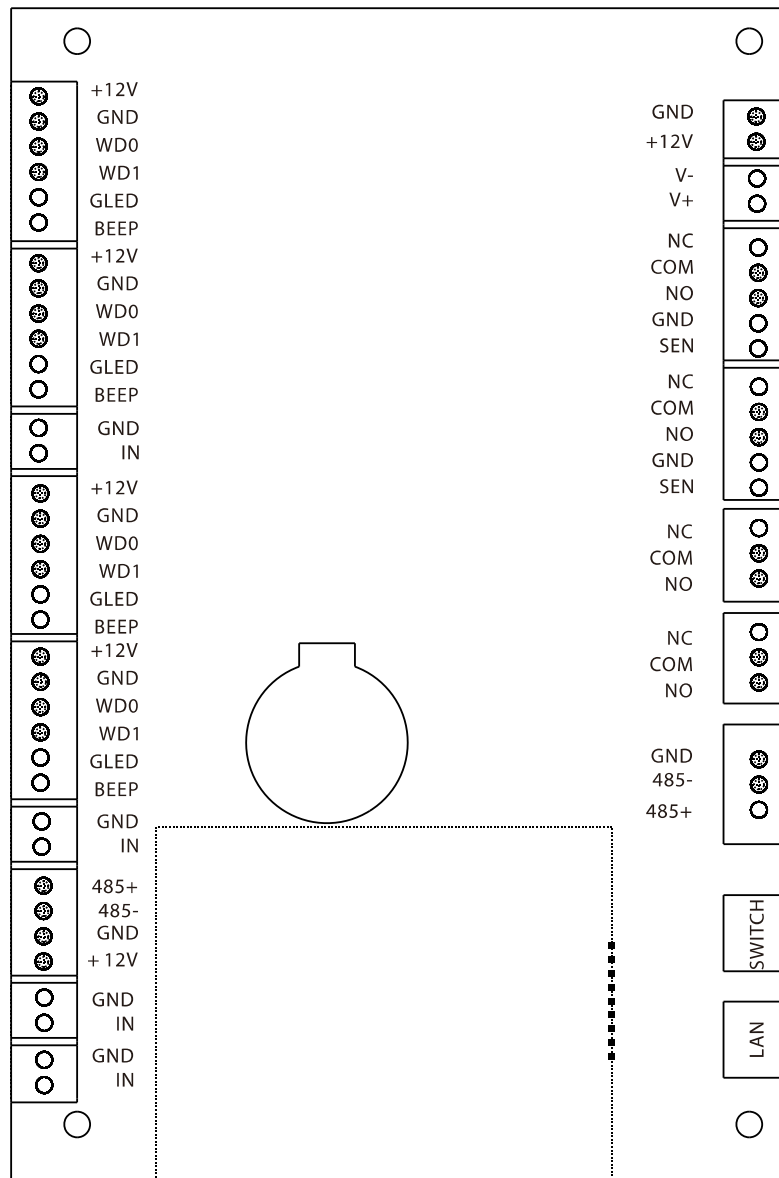

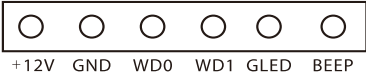





Terminal	Description
 <p>NC COM NO GND 12V</p>	Left Mode Light
 <p>NC COM NO GND 12V</p>	Right Mode Light
 <p>L1G +12V L1R</p>	Left Pass Light
 <p>L2G +12V L2R</p>	Right Pass Light
 <p>12V RX GL GR</p>	Left/Right Count
 <p>K1 COM K2 COM</p>	Left/Right Open
 <p>ALARM GND DOW COM</p>	Alarm/ Fire Signal
 <p>485A GND 485B</p>	RS485
 <p>GND 12VOUT</p>	12V Power Supply Output
 <p>VCC SEN GND +24V AUX GND</p>	Proximity Switches
 <p>24VIN GND</p>	24V Power Supply Input
 <p>V2R</p>	Reserved
 <p>V1L</p>	R-open Solenoid
 <p>UP</p>	L-Open Solenoid

3.3 Access Control Board★

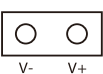
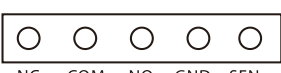
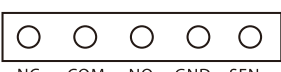

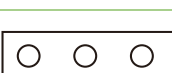
Terminal	Description
	Reader
	Reader
	Button

 <p>+12V GND WD0 WD1 GLED BEEP</p>	<p>Reader</p>
 <p>+12V GND WD0 WD1 GLED BEEP</p>	<p>Reader</p>
 <p>GND IN</p>	<p>Button</p>
 <p>485+ 485- GND +12V</p>	<p>RS485</p>
 <p>GND IN</p>	<p>Auxiliary Input</p>
 <p>GND IN</p>	<p>Auxiliary Input</p>
 <p>GND +12V</p>	<p>Power In</p>
 <p>V- V+</p>	<p>Lock</p>
 <p>NC COM NO GND SEN</p>	<p>Lock</p>
 <p>NC COM NO GND SEN</p>	<p>Lock</p>
 <p>NC COM NO</p>	<p>Auxiliary Output</p>
 <p>NC COM NO</p>	<p>Auxiliary Output</p>
 <p>GND 485- 485+</p>	<p>485 Connections</p>
 <p>SWITCH</p>	<p>Switch</p>
 <p>LAN</p>	<p>Ethernet</p>

3.4 DIP K1 Switch Configuration

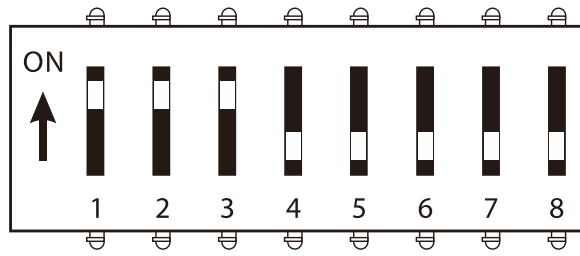

PIN	Function Setting	Description
1	Opening duration	1
2	Opening duration	1
3	Opening duration	1
4	Direction indicator	0
5	Direction indicator	0
6	Memory function	1
7	Memory function	0
8	Testing mode	0

Opening Duration			
Bit setting	Duration	Bit setting	Duration
111	5s	011	30s
110	10s	010	40s
101	15s	001	50s
100	20s	000	60s

Direction Indicator	
Bit setting	Direction
00	Passing is allowed in both directions
01	One way traffic, right passing is allow
11	One way traffic, left passing is allow
10	Both ways forbidden

Memory Function	
Bit setting	Memory
00	Unable memory function
10	Allow memory function

Alarm	
Bit setting	Solenoid automatically open and close
0	Unable auto testing
1	Allow auto testing

4 Maintenance

4.1 Chassis Maintenance

The mainframe box is made of 304 stainless steel. So after a long period of operation, its surface may have some stains. You can use a soft cotton-cloth to clean the mainframe box. In protect surface lines, please wipe along the lines direction. It's best to polish and wax it.

4.2 Movement Maintenance



Before performing maintenance, turn off the power. Open the door, wipe off any surface dust, and apply lubricant for smooth movement.

4.3 Power Supply Maintenance

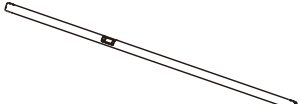
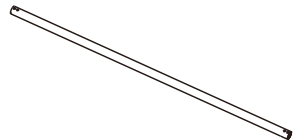
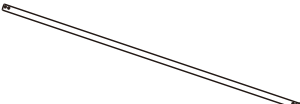

- Switch off the power supply before performing maintenance.
- Check the power plug connection, if it is loose, properly fix it.
- Do not change any connection position randomly.
- Check the external power supply insulation periodically.
- Do a periodic check for any kind of leakage.
- Check if the technical parameters of interface are normal.
- Check the service life of the electronic components and replace accordingly.

Caution: All the maintenance methods mentioned above for the Speed Gate R should be carried out by a professional technician, particularly when it comes to the movement and electric control components. To ensure operational safety, always switch off the power supply when the speed gate is not in use.

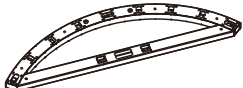
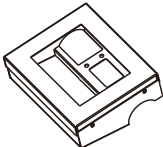
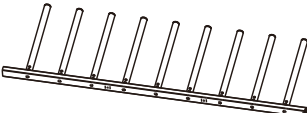
5 Packing List

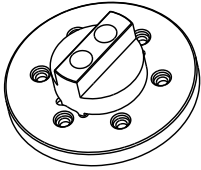
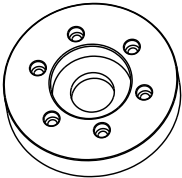
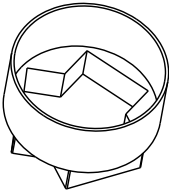
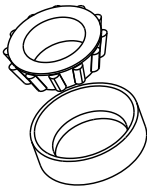
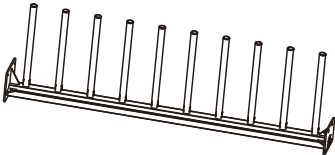
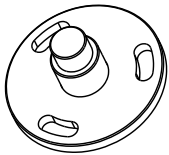
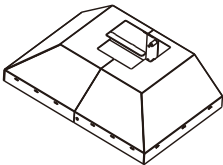
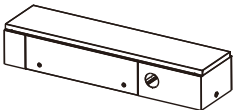
	Item	Number
	Left Side Welded Fence Assembly (51 Rods)	1
	Right Side Welded Fence Assembly (51 Rods)	1
	Center Welded Fence Assembly (51 Rods)	1
	38-Bar Fence Assembly	6
	Fence Bottom Beam	1
	Fence Top Beam	1
	Authentication Box	2
	Square Shaft with 9-Bar Rotor Assembly	3

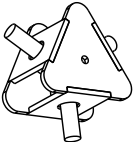
	<p>Shaft End Cap</p>	<p>1</p>
	<p>Shaft Bottom Sleeve</p>	<p>1</p>
	<p>Shaft Guard</p>	<p>1</p>
	<p>Tapered Roller Bearing for Shaft</p>	<p>1</p>
	<p>Square Tube Right Angle Bracket for Fence Frame</p>	<p>1</p>
	<p>Shaft Base</p>	<p>1</p>
	<p>Base Box</p>	<p>1</p>
	<p>Mechanism Housing</p>	<p>1</p>

	Mechanism Shaft Sleeve	1
	Left Fence Guard	1
	Right Fence Guard	1
	Socket Head Cap Screw (M8x25mm)	12
	Socket Head Cap Screw (M5x12mm)	8
	Pan Head Screw with Washer (M4x6mm)	4
	Shaft Fixing Block	2
	Lock Nut (M5)	6
	Hole Plug	12
	Socket Head Cap Screw (M6x20mm)	12
	Spring Washer (M6xT1.6mm)	12

	Internal Expansion Anchor (100x16xM12mm)	11
	Ground Silicone Bumper	4
	Flat Head Phillips Screw (M3x6)	3
	Socket Head Cap Screw (M10x60mm)	4
	Socket Head Cap Screw (M10x30mm)	4
	Hex Socket Flat Point Set Screw (M6x10)	2
	Socket Head Cap Screw (M6x16mm)	6
	T-Handle Ratchet Wrench (100x83x6.35mm)	1
	Magnetic Bit Holder (90x6.35mm)	1

	Maintenance Manual	1
	Keys	2
	Stainless Steel Cleaning Wipes	2

ZKTeco Industrial Park, No. 32, Industrial Road,

Tangxia Town, Dongguan, China.

Phone : +86 769 - 82109991

Fax : +86 755 - 89602394

www.zkteco.com

