

Installation Guide

Saturn-S4000 Series

Applicable Model(s): Saturn-S4000, Saturn-S4200

Version: 1.0

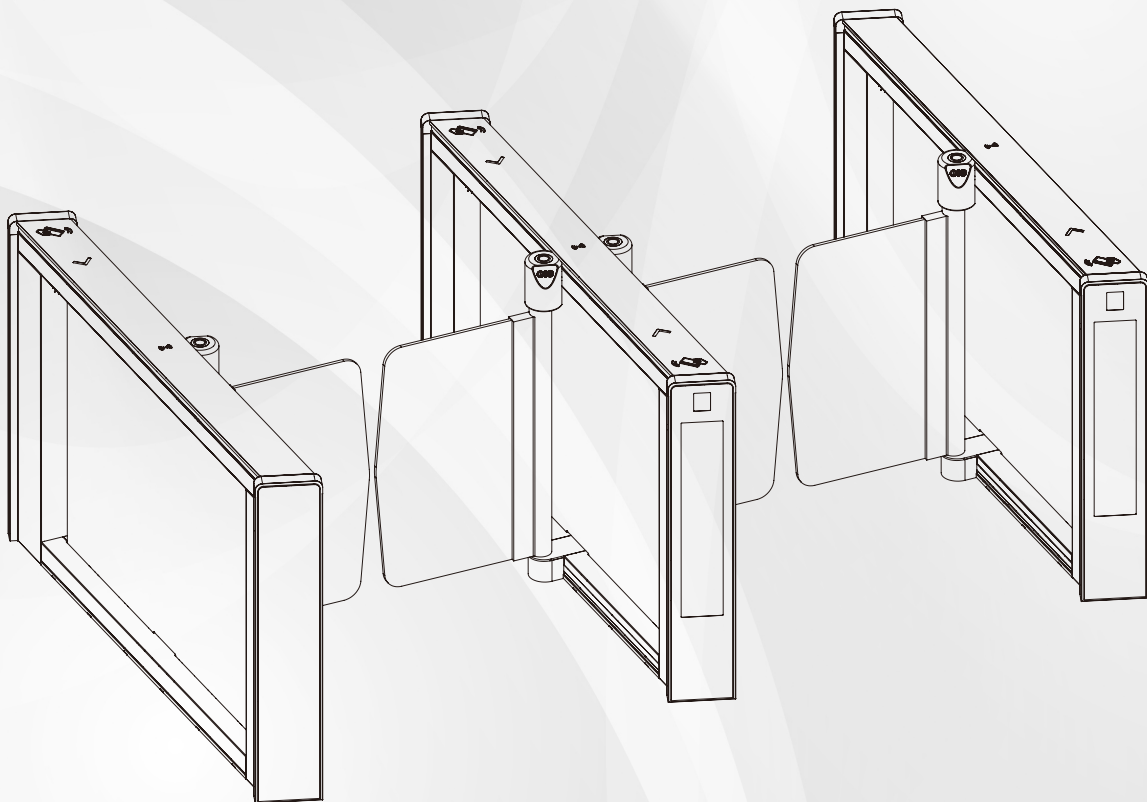

Revision History

Revision	Date	Author	Reviewer	Description
V1.0	29/12/2025	Julia Huang		Original Document
V1.0	24/03/2026	Stella Xia		Modify the parameters

1 Overview

Saturn-S4000

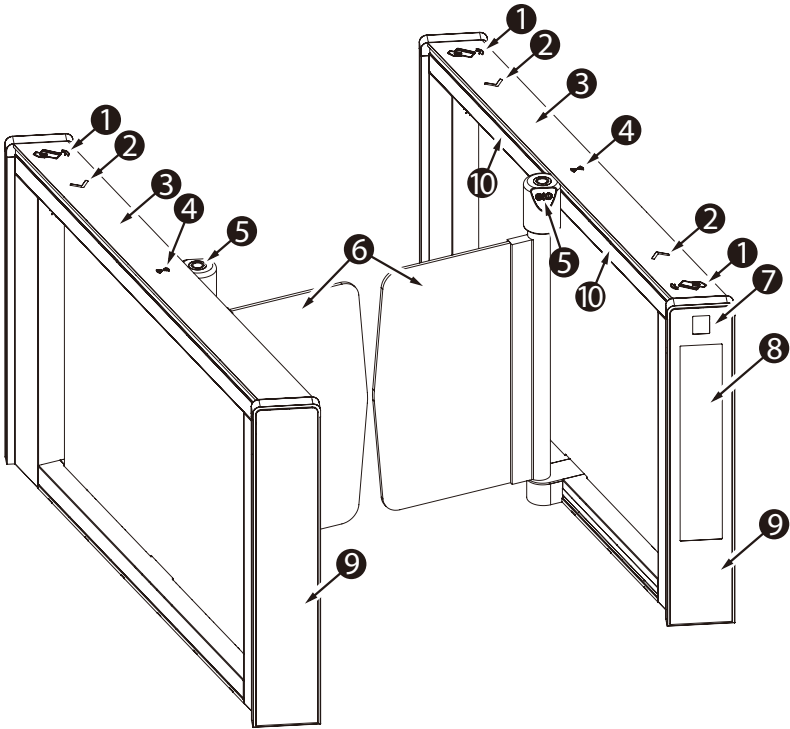

Saturn-S4200

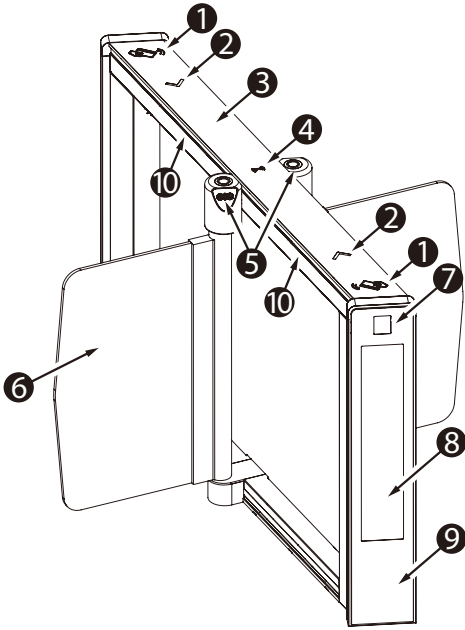

- ① Card Reading Area
- ② Traffic Indicator
- ③ Top Lid
- ④ NFC (optional)
- ⑤ Multimodal Camera (optional)
- ⑥ Door Leaf
- ⑦ QR Code Module
- ⑧ LCD Screen
- ⑨ Side Pedestal
- ⑩ Infrared Sensor

2 Dimensions

Saturn-S4000

Unit: mm

Front View

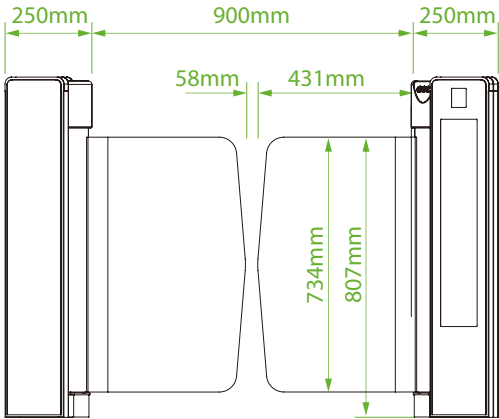

Side View

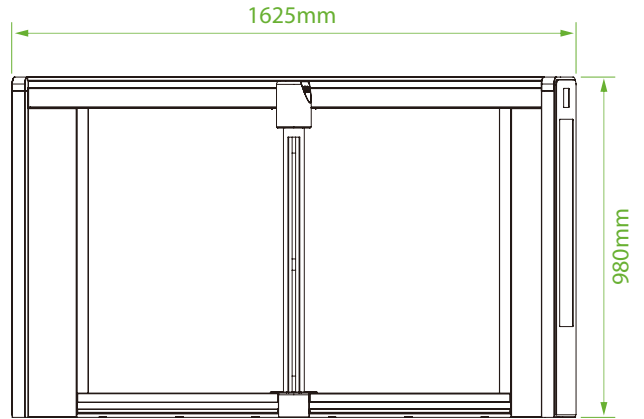

Top View

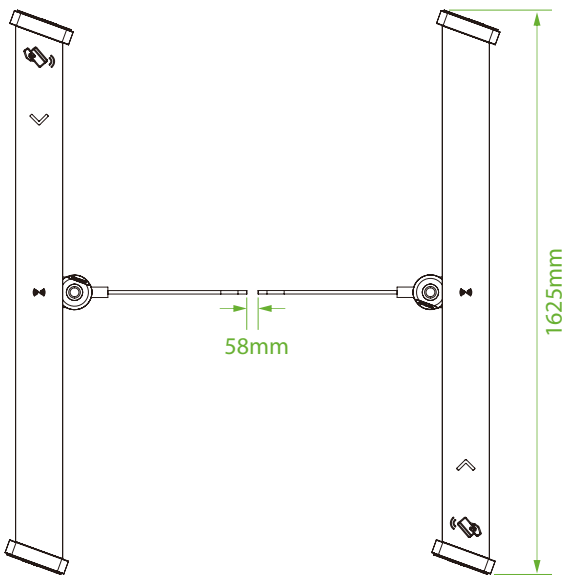

Bottom View

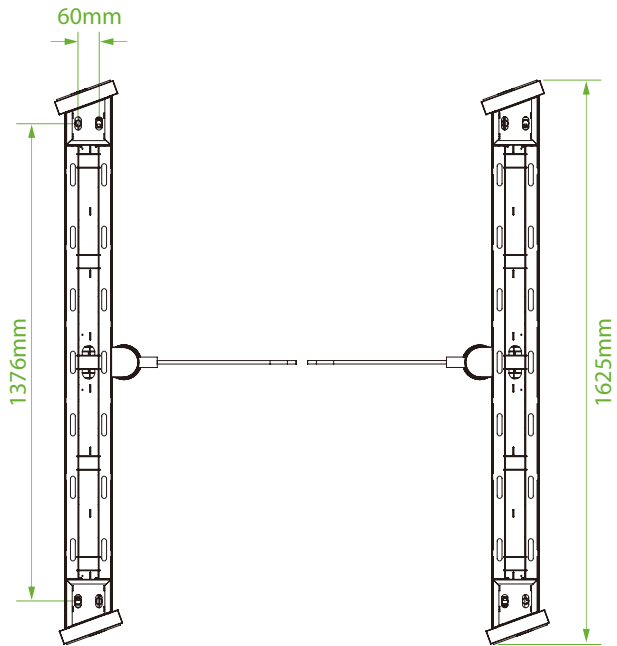

Saturn-S4200

Unit: mm

Front View

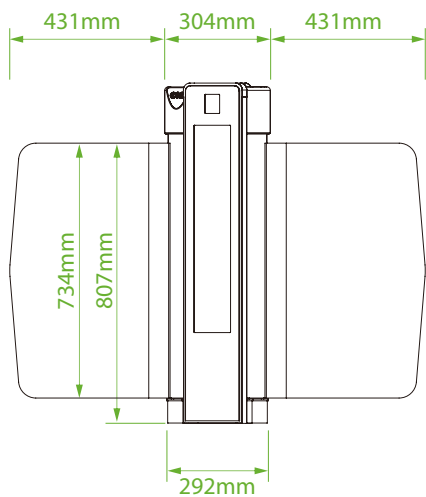

Side View

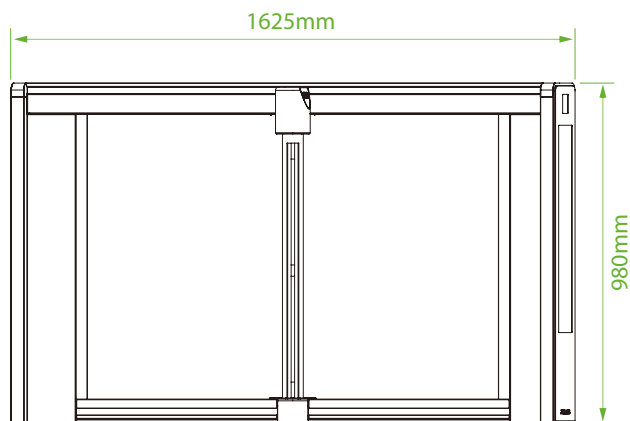

Top View

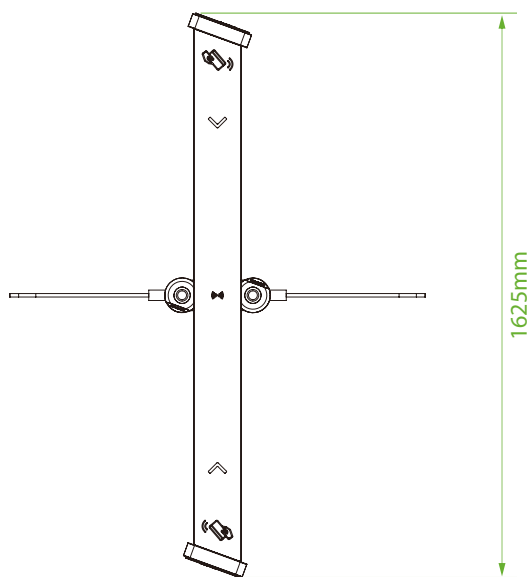

Bottom View

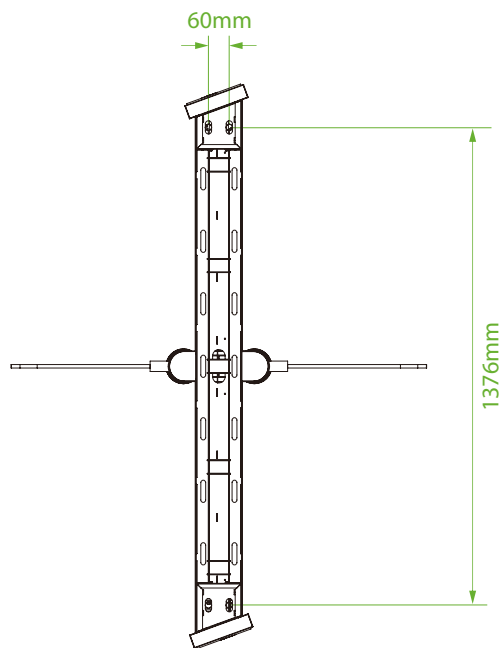

3 System Composition

The Saturn-S4000 and Saturn-S4200 can be combined to form a single, dual or multi-lane system, allowing the user to select the appropriate swing arm size according to actual needs. It should be noted that Saturn-S4200 needs to be used in conjunction with Saturn-S4000.

● Single-lane

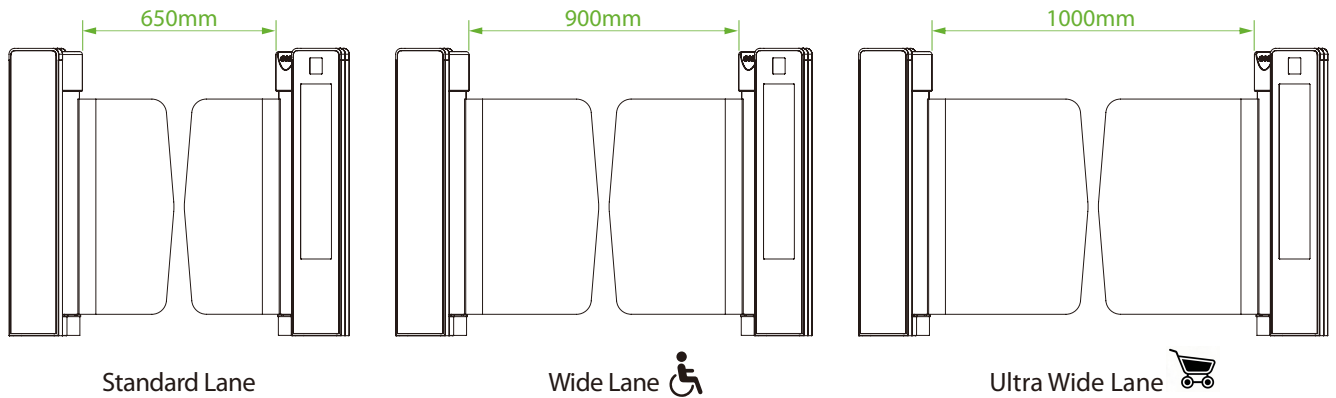

● Dual-lane

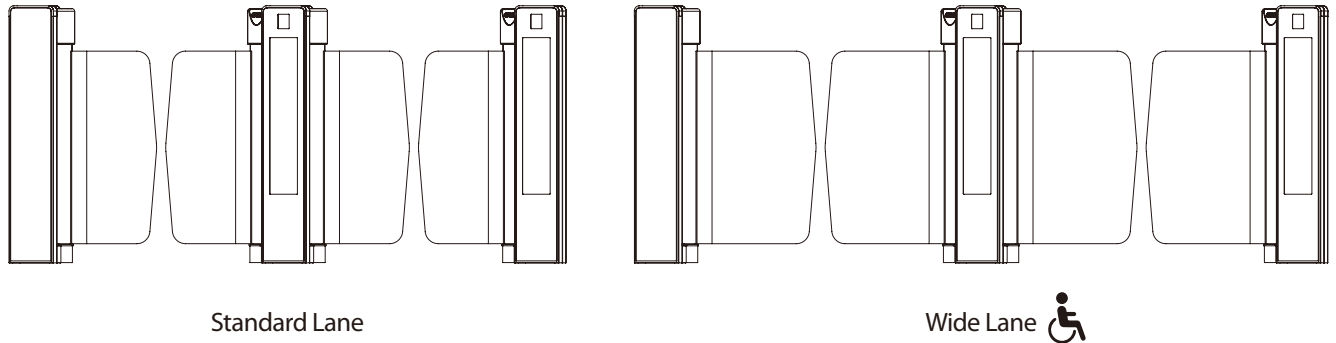

● Multi-lane

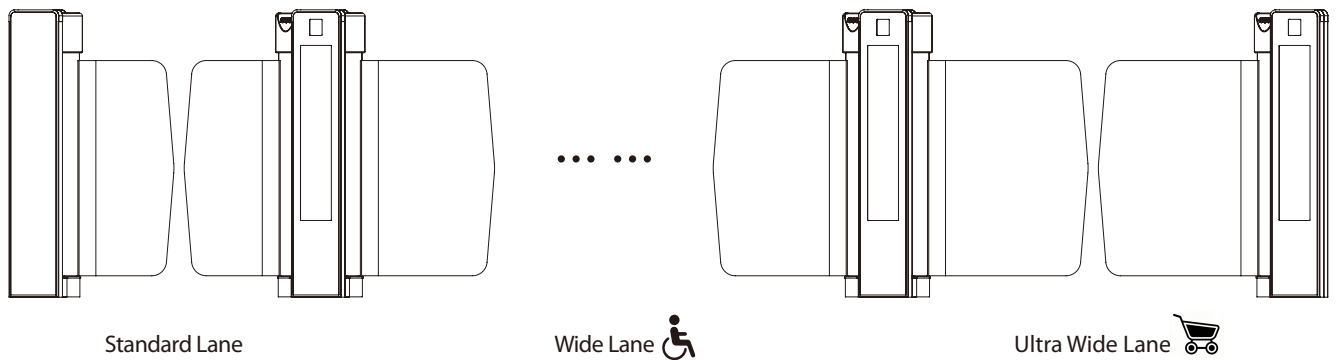

4 Wiring

● Single-lane wiring

Secondary device

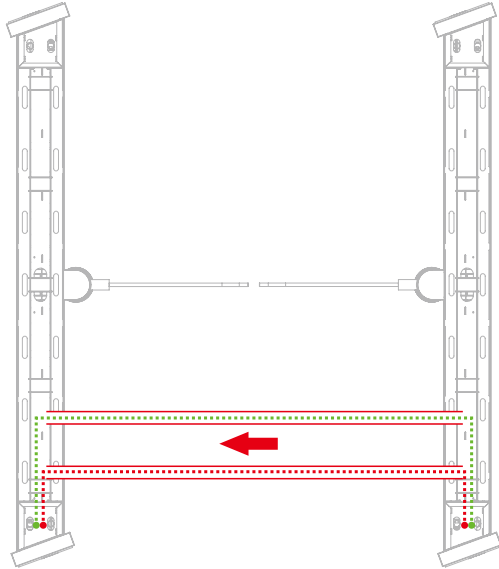

Primary device

●●●●●●●●
2-core connecting wire(M-S)

●●●●●●●●
PowerCable AC110/220V input

● Dual-lane wiring

Secondary device

Secondary device

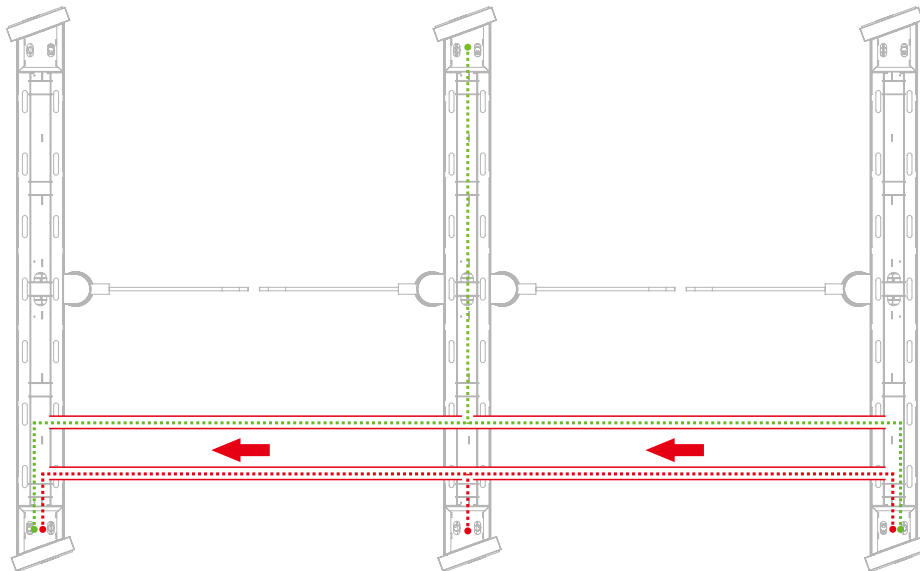

Primary device

Primary device

Remarks: The multi-lane wiring method is similar.

5 Installation Requirements

1. It is recommended that the turnstile must be installed on a horizontal solid platform with a height of **2.0" to 3.9"(50mm to 100mm)**.
2. It is recommended that the turnstile should not be used in the corrosive environment.
3. Make sure that the ground wire of the system is securely connected to avoid personal injuries or other accidents.
4. After installation, check if the connection has been done correctly at the connecting points of the ground wire, at the connector assemblies and wiring points of the circuits, as well as at each movable part of the turnstile. Any loose nuts, screws and other fasteners should be tightened in time to avoid any failures caused by long-time operations.

6 Installation Environment

1. Before installation begins, prepare installation tools, check the device and the accessories, and clear the installation base.
2. Make sure that the appliance is mounted on a concrete surface or other non-flammable surfaces.
3. The installation position of the turnstile depends on its size. A distance of **3.9"(100mm)** between the turnstile and the wall needs to be reserved for ease of opening the top lid of the turnstile to perform maintenance and adjustment. The reference figure is shown below:

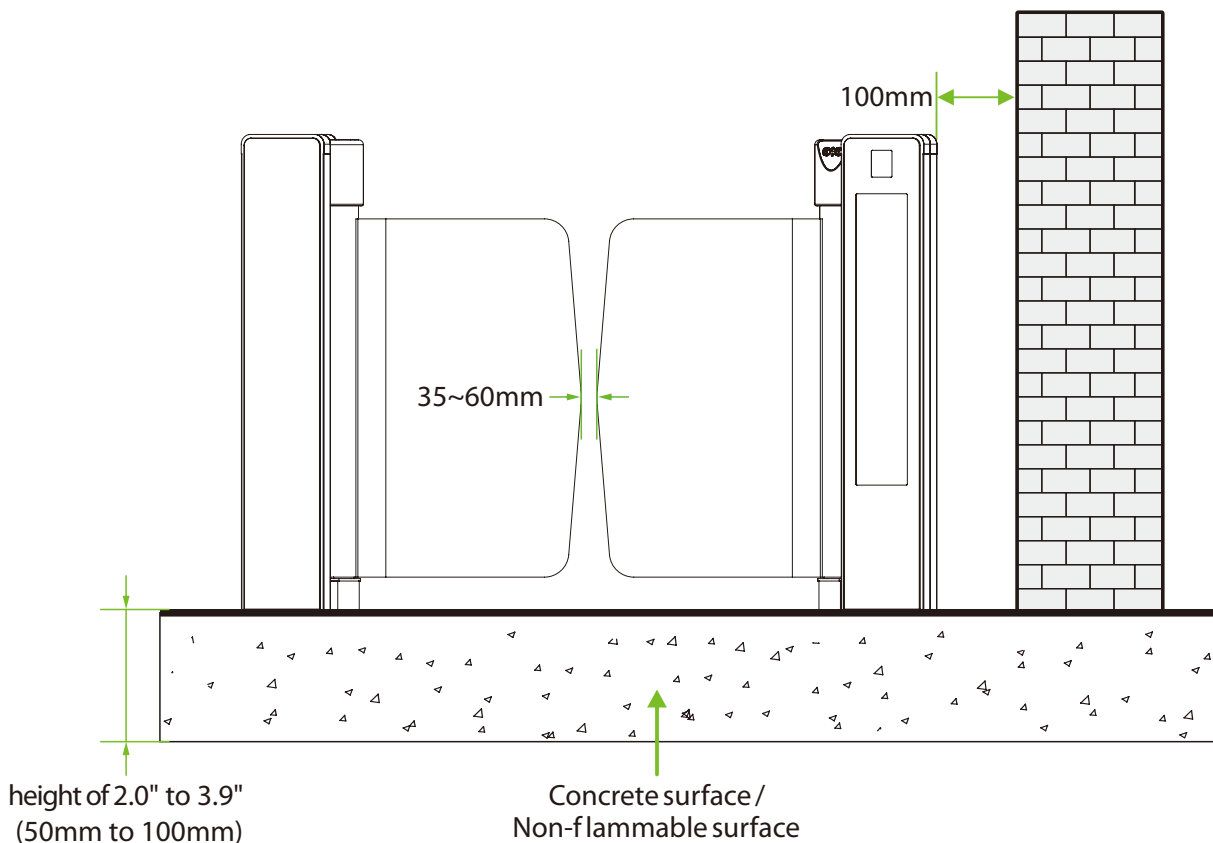

7 Installation Cabinet

Step 1 Remove the Top Lid

1. Use a screwdriver to loosen the two fixing screws at the indicated locations, then remove the top lid in the direction shown.

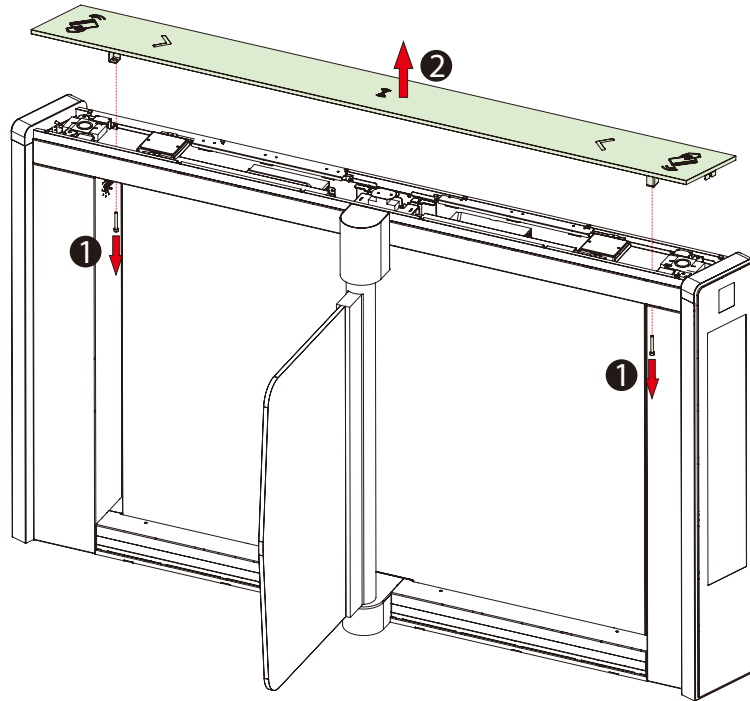

2. Loosen the screws and the readers as shown in the figure below.

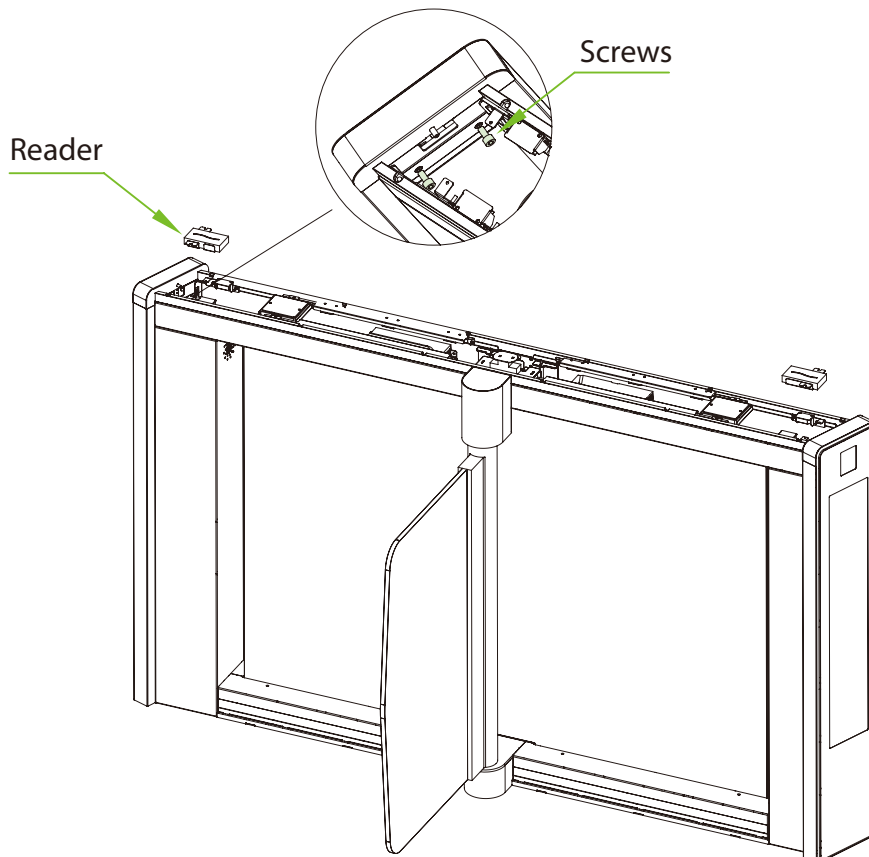

Step 2 Remove the Side Pedestal

Push the side pedestal on both sides upward and then remove them.

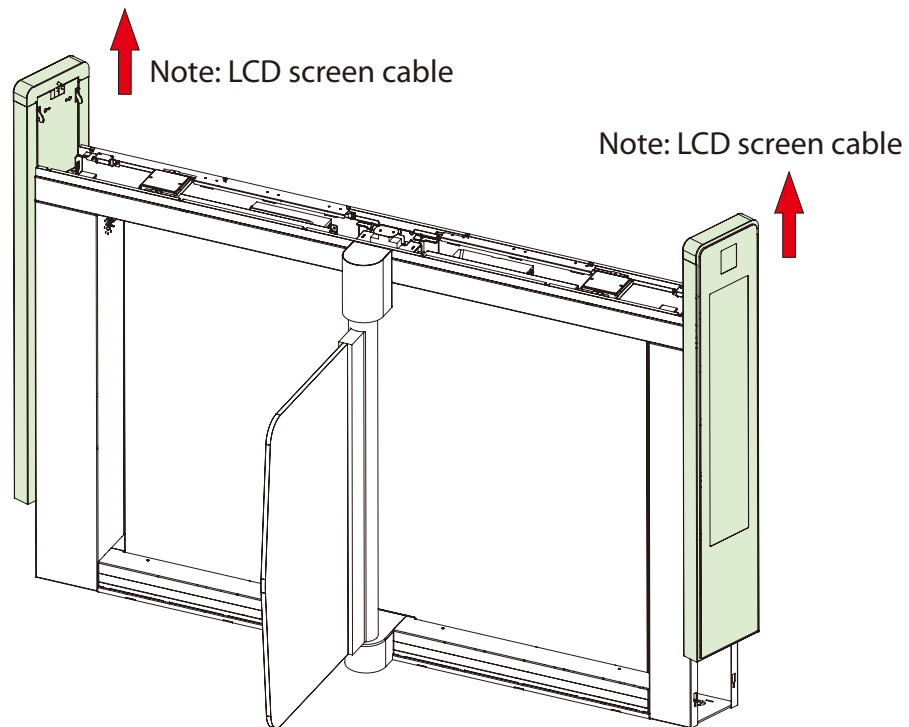

Step 3 Marker Position

1. Draw the location of the cabinet with a marker and mark each location of the mounting holes. There will be a total of four mounting holes and two wire holes per cabinet.
2. Remove the cabinets when finished.

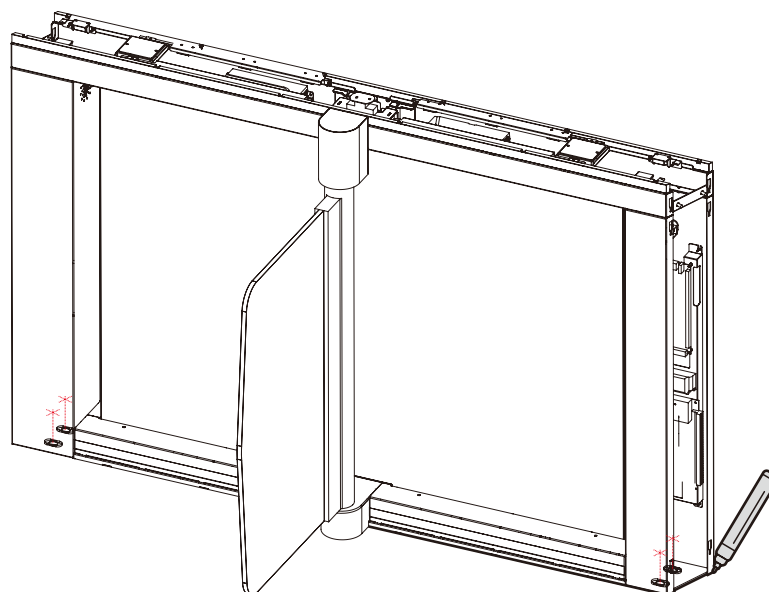

Step 4 Determine the Mounting Location

1. Please refer to the user's manual and complete the **power-on self test** operation before installation.
2. Then place the cabinet according to the mounting distances shown in the diagram below. Take care to measure the distance between the bottom inside walls of the cabinets on the entrance side and exit side of the channel and make sure that the measurements are consistent.

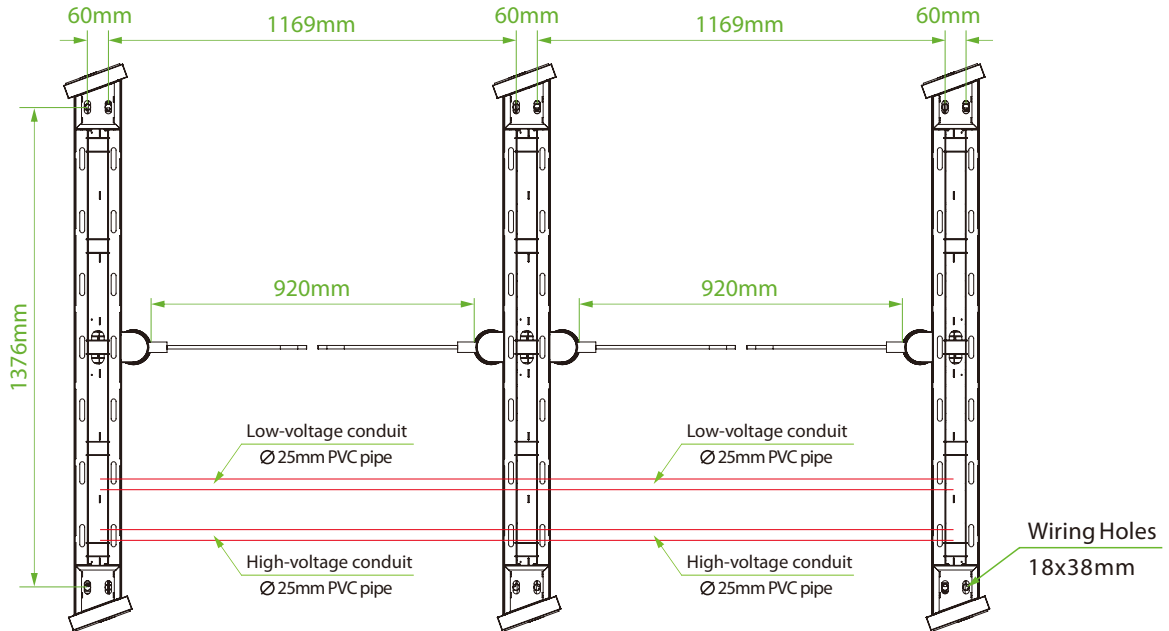

Wide Lane 

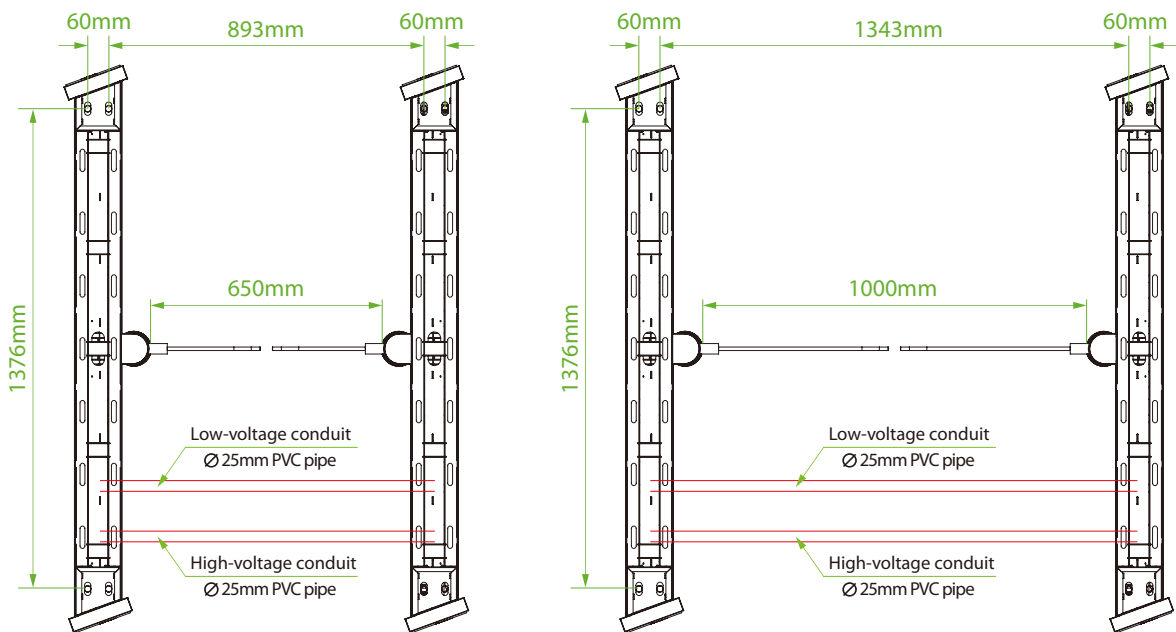

Standard Lane

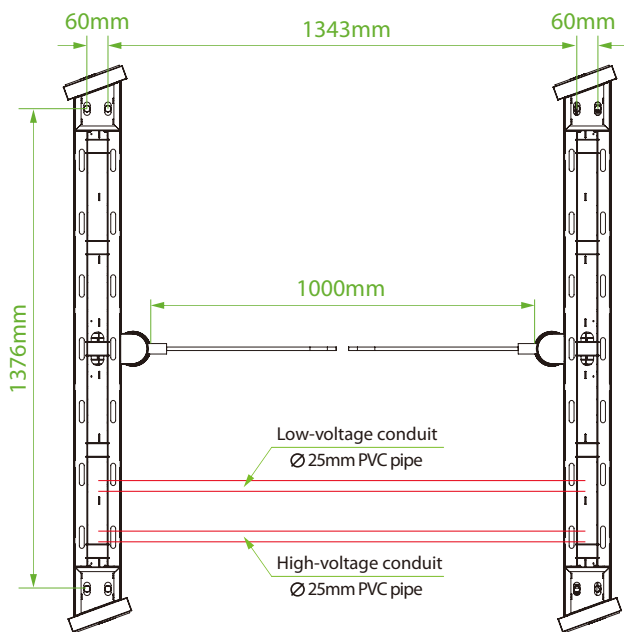

Ultra Wide Lane 

Step 5 Drill Holes and Place Bolts

1. Using a concrete drill bit, drill the mounting holes **2.0" (50mm)** in depth at the center of each marked location.
2. Then insert the bolts vertically into the mounting holes as shown at right.
3. Make sure the bolts are placed in place. Use a hammer to tap the bolts into place, if needed.

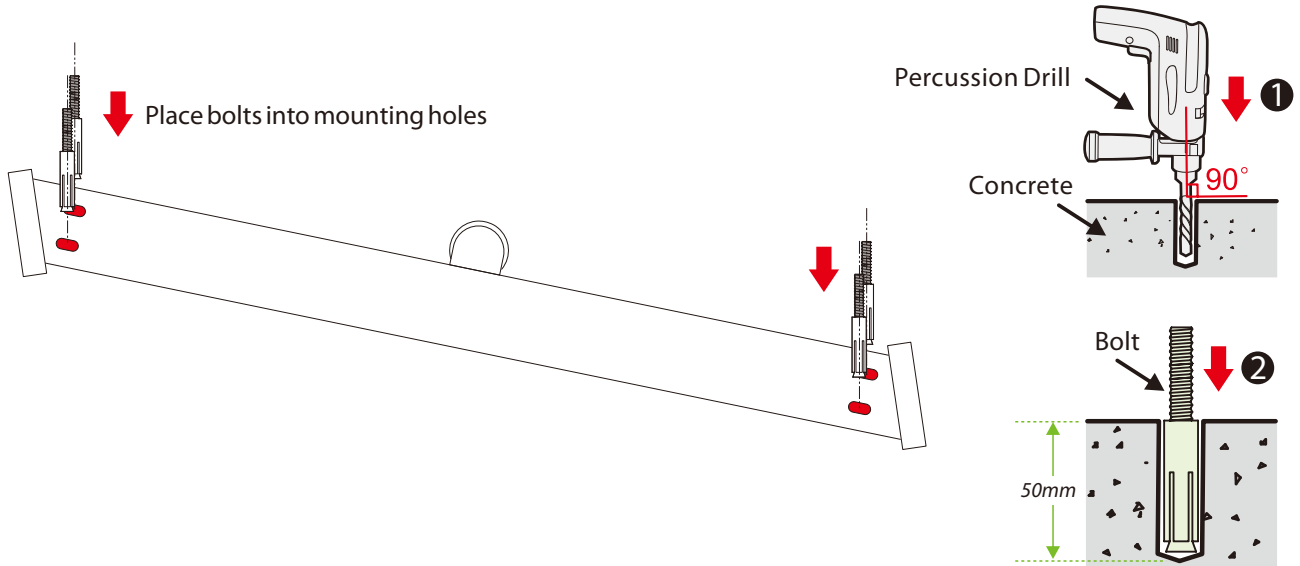

Step 6 Wireway Laying

1. Dig a recess of **2.0" (50mm)** depth between the wire holes on both sides of the channel with the dimensions shown below. Recesses can be dug at positions **1** and **2**.
2. Then lay two **0.8" to 1.0" (20 to 25mm)** diameter PVC pipes as shown below.
3. After threading the cable out of the PVC pipe, pour concrete to fix it in place.

Top View

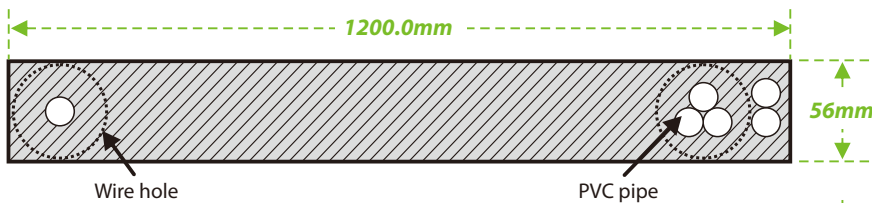

Side View

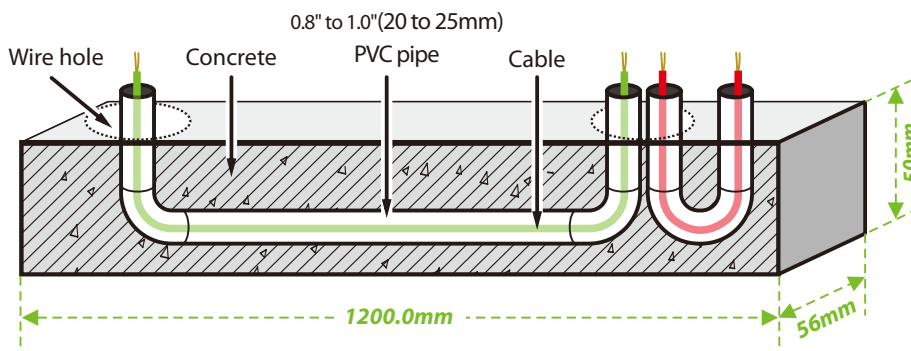
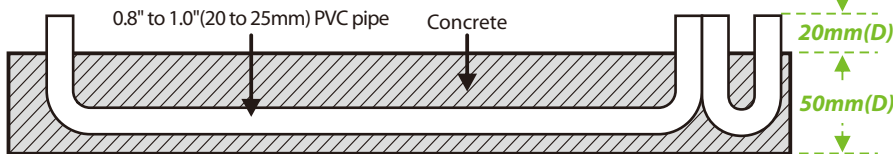

Position of the notch:

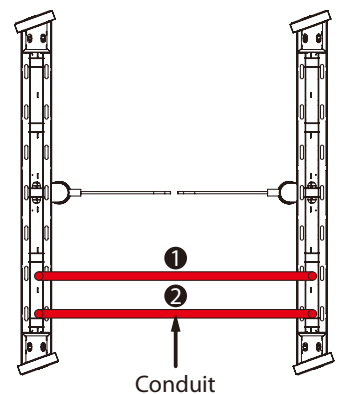

- 2-core Connecting Wire (M-S)
- Power Cable AC110/220V input

Step 7 Secure the Cabinet

1. After laying the PVC pipe, place the cabinet alignment bolts back into the mounting position.
2. Then insert the eight washers and nuts into the bolts one by one.
3. Tighten the nuts to hold the cabinet in place. Don't tighten it completely until after you're sure it won't move anymore. The finished result is shown below:

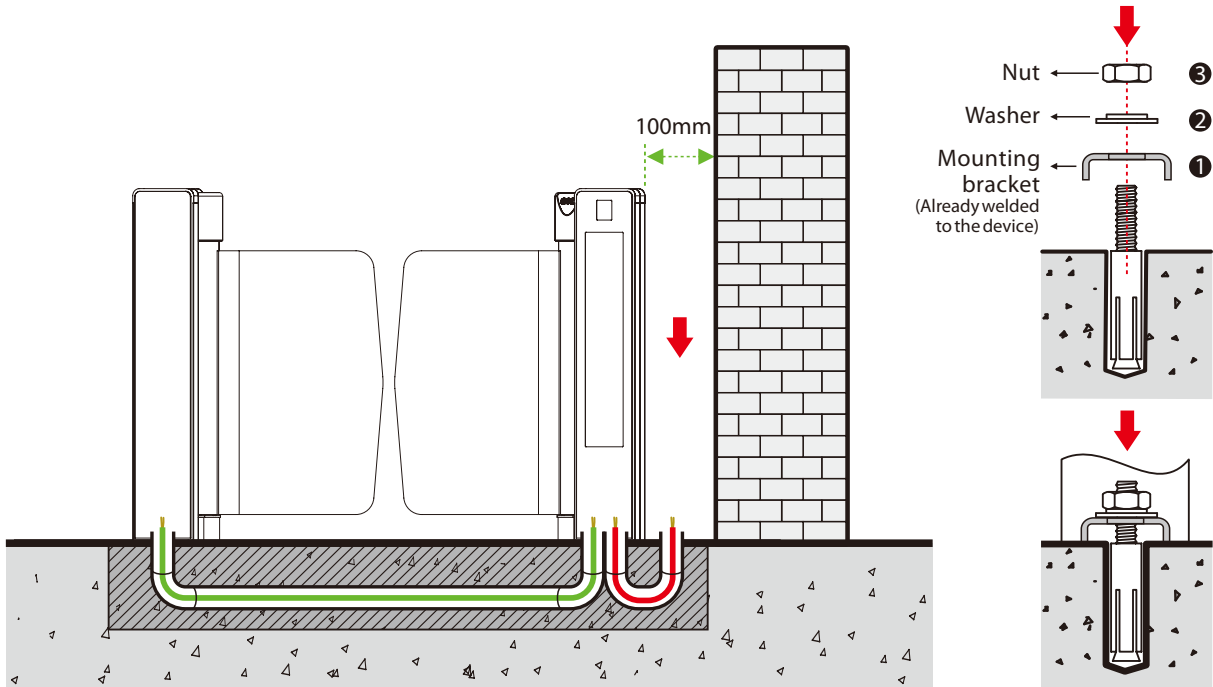

Step 8 Marking the Warning Line

1. It is recommended that warning lines be marked on the ground and used to alert users.
2. A warning line can alert users to wait outside the line until the previous user completes the verification process and passes through the turnstile.

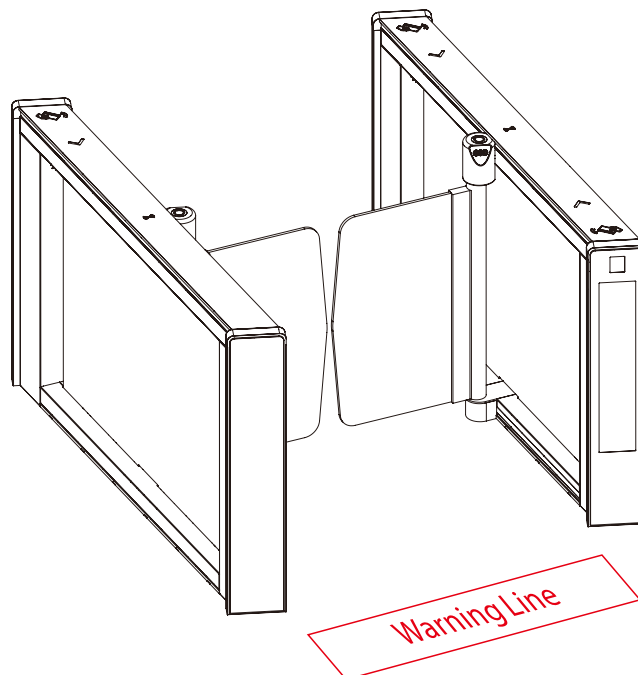

8 Wiring Diagram

Multimodal + dToF Sensor Version

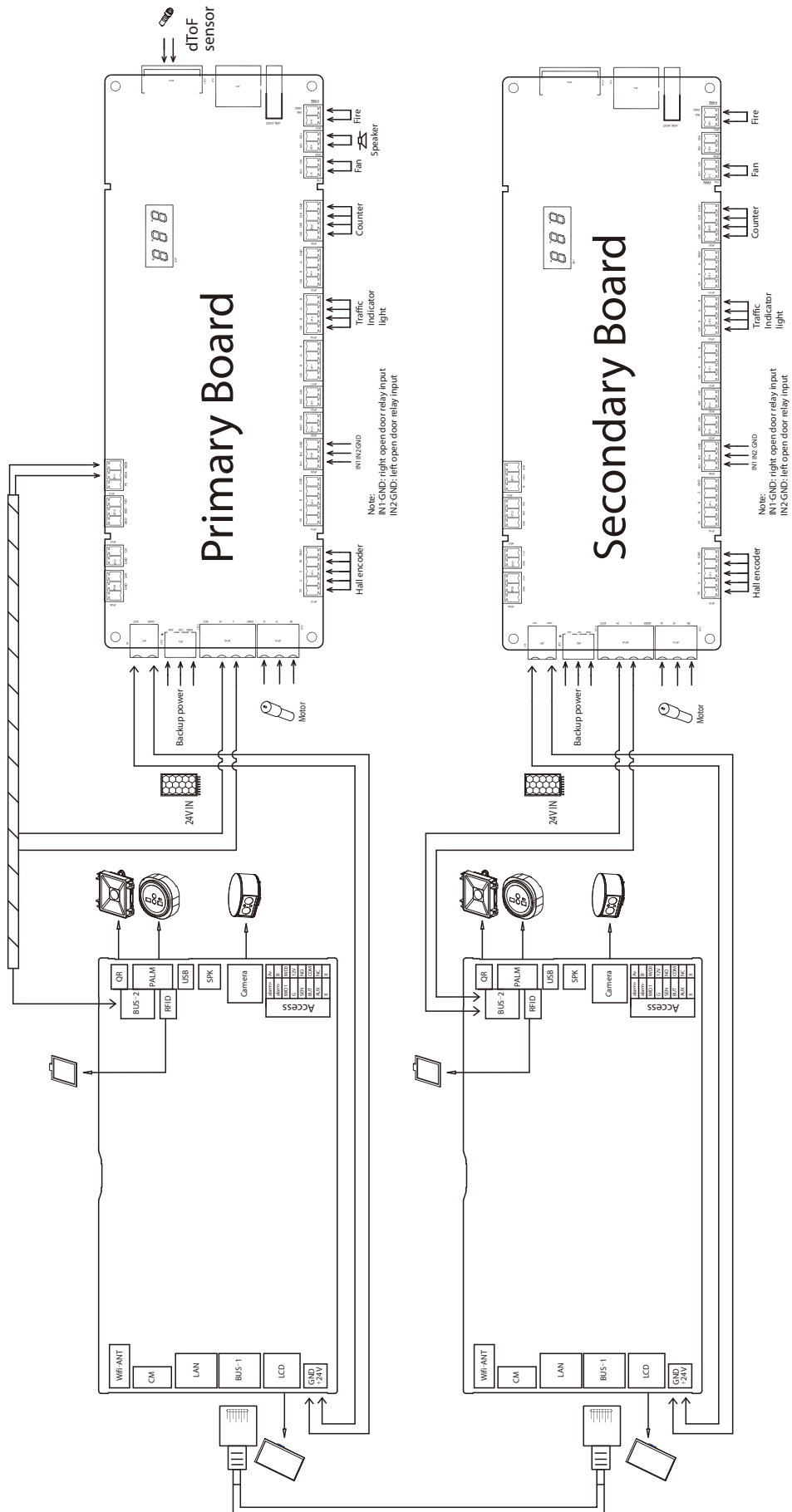

dToF Sensor Standard Version

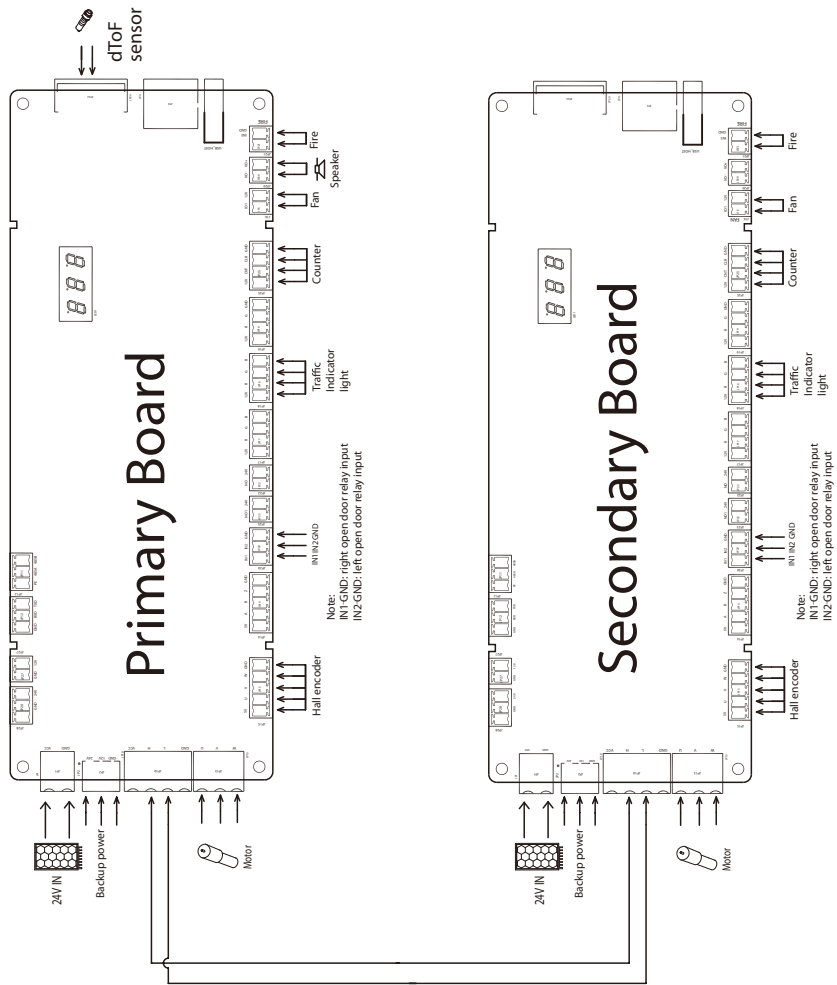

ZKTeco Industrial Park, No. 32, Industrial Road,

Tangxia Town, Dongguan, China.

Phone : +86 769 - 82109991

Fax : +86 755 - 89602394

www.zkteco.com

